



Compact IITM

Raritan's most economical toilet. Great value in a low-priced manual toilet.

Benefits

- Fits in small spaces – ideal for small sailboats and powerboats
- Easy and quiet operation – no complicated hand or foot valves
- Simple and flexible installation for mounting above or below waterline
- Requires no electricity
- Conserves water – boaters can switch to dry pump option
- Quiet operation
- Easy to clean and maintain
- Proven, dependable design
- Powerful flushing action
- Has all the features of more expensive toilets
- Can be used with on-board treatment systems (such as the Lectra/San[®]) and/or holding tanks
- Each unit is assembled by hand, individually tested and backed by Raritan's one-year Limited Warranty and legendary technical support team

Compact II™

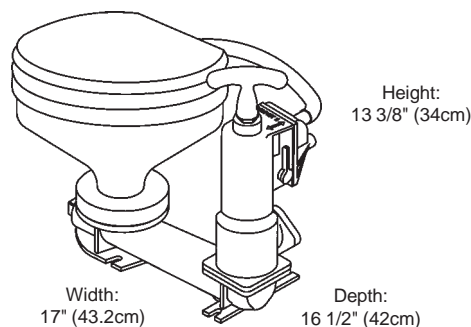

Approximate Shipping Weight: 26 lbs (12 kg)

Raritan kept the concept of space conservation that made the original model Compact ideal for fitting a real toilet into a very small area. The re-engineered Compact II toilet still meets the demand for small space but offers improved flushing efficiency and simpler maintenance. The Compact II presents a better appearance and provides improved performance at an economical price.

The new "T" grip handle provides control over the flushing action by allowing the user to fully grip the handle and pump. The longer shaft provides improved flush volume. A redesigned cartridge-type seal extends the life of the toilet and simplifies routine maintenance. The snap-together shutoff/dry flush valve improvement allows the user to evacuate the bowl in turbulent waters with no vacuum resistance within the pump. Injection-molded check-valve housing accommodates both intake and discharge hoses, keeping all connecting hoses to the rear of the toilet.

The Compact II is designed for easy assembly and disassembly for maintenance. The standard 1½" discharge hose fitting is compatible with treatment devices or holding tanks. The Compact II is an ideal replacement for portable toilets.

Additional parts that are needed for installation: Hose clamps, four stainless steel mounting bolts (minimum ¼" [6mm]) or lag screws and washers, 1½" (38mm) I.D. sanitation hose, and ¾" (19mm) I.D. sanitation hose.

Model

Part#	Description
CPII	Compact II Hand Toilet
CPIIRFK	Compact II Retrofit Kit (converts Compact to Compact II)
CPIIPUMP	Compact II Pump Assembly Complete

Sample Installation

The Compact II can be installed above or below the water line. For mounting at or below the water line, a **vented loop must be included in the installation between the bowl and the pump**. All thru-hull fittings should include readily accessible seacocks for safety and simplification of maintenance. (This recommendation is made by the American Boat and Yacht Council [ABYC] and marine underwriters for all installations.) The Compact II can be easily combined with the Lectra/San or a holding tank for a complete U.S. Coast Guard approved sanitation system.

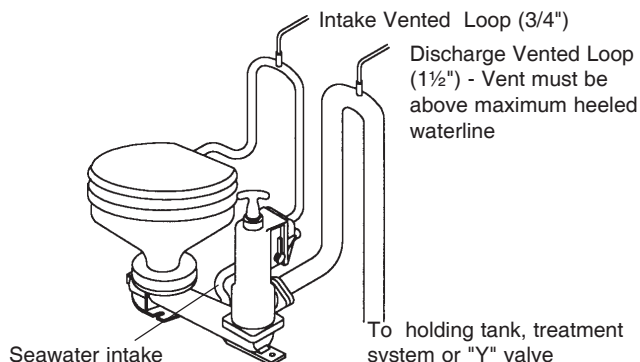

Below Waterline Installation