

Hold n' Treat Holding Tank Processor

Installation and Maintenance Instructions

THE FOLLOWING ARE CAUTIONARY STATEMENTS THAT MUST BE READ AND FOLLOWED DURING BOTH INSTALLATION AND OPERATION

WARNING: *Raritan Engineering Company, Inc. recommends that a qualified person or electrician install this product. Equipment damage, injury to personnel or death could result from improper installation. Raritan Engineering Company, Inc. accepts no responsibility or liability for damage to equipment, or injury or death to personnel that may result from Improper installation, trouble shooting, repairs to or operation of this product.*

WARNING: **HAZARD OF SHOCK AND FIRE** - Always use recommended fuse/circuit breaker and wire size. The components are not ignition protected and must not be installed in a gas engine room or exposed to the possibility of spark.

For use with Lectra/San MC manufactured August 2004 and later (Last four digits of serial number 0804) and Purasan model numbers PST1203 or PST2403. Contact customer service to update their current Lectra/San or Purasan.



The 'Hold n' Treat' is designed to integrate both a Type I and Type III MSD (Marine Sanitation Device) to provide the user with a system that will be legal in all areas. The basic system consists of the lock-out switch, controller, tape for the holding tank and a pump relay. A complete system will consist of: a holding tank, macerator pump, lock-out switch, controller and Lectra/San MC or Purasan. Raritan has a variety of tanks enabling users to "build" a complete system.

All waste is stored in a holding tank and the key switch position will determine how the waste is processed. This system eliminates the need for pump-out stations in most areas.

OVERVIEW

When 'Hold n' Treat' is set to AUTOMATIC the level of waste in the holding tank is monitored (every 30 seconds). Once the waste level reaches the HIGH LEVEL the 'Hold n' Treat' Control Unit sends a signal activating the Lectra/San MC or Purasan. The Lectra/San MC or Purasan, in turn, activates a macerator pump which moves waste (approximately 1 gallon) from the holding tank to the Lectra/San MC or Purasan. This cycle is repeated approximately every seven minutes. After the fourth cycle, the system enters a *cool down* cycle. It will remain in the *cool down* cycle for approximately fifteen minutes. After *cool down*, the process will resume until the waste in the tank drops below LOW LEVEL.

Important

- When 'Hold n' Treat' is activated, ensure the Lectra/San MC or Purasan is operating properly. Refer to the Lectra/San MC or Purasan Manual for proper operation.
- Use of certain chemicals in toilet or holding tank will cause damage to the Lectra/San MC or Purasan. We recommend ONLY Raritan C.P. Cleans Potties and Raritan K.O. Kills Odors.
- A KEY SWITCH is provided to prevent activation of the 'Hold n' Treat when in No Discharge Zones. However, placing KEY SWITCH in the NO DISCHARGE Position and removing the KEY should not be considered the only means of securing an MSD when in a No Discharge Zone.

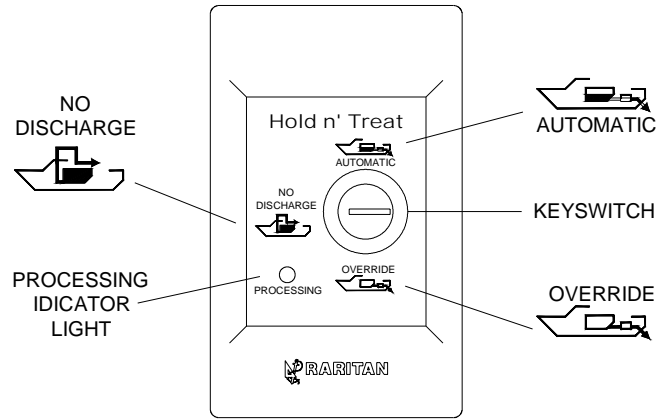

PROCESSING INDICATOR LIGHT

When key switch is in automatic position:

- blinks when level is above HIGH LEVEL
- on solid between HIGH and LOW LEVEL
- off once below LOW LEVEL

When key switch is in no discharge position:

- light will not be active

When key switch is in override position:

- blinks all the time

Where discharge of treated waste is allowed

- Turn KEY SWITCH to AUTOMATIC. Waste in holding tank will be processed automatically once HIGH LEVEL is reached and will stop once LOW LEVEL occurs.

Before entering a No Discharge Zone

- Turn KEY SWITCH to OVERRIDE. The system will process waste until key is turned to no discharge or automatic position. Allow approximately 1 hour per 6 gallons of waste to be treated. **Important:** When in override - Hold n' Treat will not shut off automatically, the system must be monitored and turned off once tank is emptied.

Once in a No Discharge Zone

- Turn KEY SWITCH to NO DISCHARGE Position and remove KEY. 'Hold n' Treat' will be off. Removing Key from Key Switch ensures 'Hold n' Treat' will not be turned on and discharge treated waste. All waste will be stored in the holding tank while in the No Discharge Zone.

Operation in EPA designated No Discharge Zones affects the MSD installation on every vessel that enters or stays in those waters. Flow-through devices are permitted if adequately secured to prevent discharges of any sewage, treated or untreated. Closing the seacock and padlocking, using a non-releasable wire-tie, removing the seacock handle would be sufficient means of securing. Owner/operators should determine whether the intended area of operation is a No Discharge Zone.

Parts included

212B00 Key Switch Panel

- Key Switch plate assembly Bezel
- 4 #4 x 1/2" screws (surface mounting)
- 2 #6 x 1" screws (receptacle mounting)
- Gasket
- 2 Keys

213B* Control Unit

214* Macerator Pump Relay

15300 Tank Sensor Modules

15310 Aluminum Foil Tape (5 foot [1.5m])

EF5 5 Amp Fuse with In-Line Holder

21202 Replacement key

***specify voltage**

MAINTENANCE

Refer to Lectra/San MC or Purasan and Macerator Pump Manuals for Maintenance Instruction

Important: Use of certain chemicals in toilet or holding tank will cause damage to Lectra/San MC or Purasan. Refer to Lectra/San MC or Purasan Manual concerning their use.

WINTERIZING

Disconnect or shut down power to unit. Refer to Lectra/San MC or Purasan and Macerator Pump Manuals for Winterizing Instruction

Important: Remove antifreeze if used from holding tank before activating 'Hold n' Treat'.

SPECIFICATIONS

Refer to Lectra/San MC or Purasan and Macerator Pump Manuals for Specifications

Electrical Controls Only:

12VDC 1 AMP

24VDC 1 AMP

Treatment Capacity:

140 gallons (530 liters)/week

'Hold n' Treat' processes approximately six gallons (23 liters) per hour.

NOTE:

Discharge of raw, untreated sewage is prohibited in all U.S. waters inside the three mile limit except in the Gulf of Mexico where the limit is nine miles. "Y" valves, if installed, must direct toilet discharge to a U.S.C.G. approved treatment system or holding tank and must be secured in that position while inside the three-mile limit.

The EPA standards state that in freshwater lakes, freshwater reservoirs or other freshwater impoundments whose inlets or outlets are such to prevent the ingress or egress by vessel traffic subject to this regulation, or in rivers not capable of navigation by interstate vessel traffic subject to this regulation, marine sanitation devices certified by the U.S. Coast Guard installed on all vessels shall be designed and operated to prevent the overboard discharge of sewage, treated or untreated, or any waste derived from sewage. The EPA standards further state that this shall not be construed to prohibit the carriage of Coast Guard-certified flow-through treatment devices which have been secured so as to prevent such discharges. They also state that waters where a Coast Guard-certified marine sanitation device permitting discharge is allowed including coastal water estuaries, the Great Lakes and interconnected waterways, freshwater lakes and impoundments accessible through locks, and other flowing waters that are navigable interstate by vessels subject to this regulation (40 CFR 140.3)

INSTALLATION

IMPORTANT: Read all instructions before proceeding with installation.

Hold n' Treat instructions describe installation of the components contained in the kit. For instructions regarding installation, operation and maintenance of the other components (Lectra/San or Purasan, Pump, . . .) refer to their respective manuals.

WARNING: Not certified for use in an explosive environment.

Mounting the Key Switch Panel

Note: Several options available for mounting the Key Switch Panel

- Choose a location that is easily seen, accessible and not exposed to the weather
- Locate where wires can be routed
- Minimum depth of 1 1/2" (4 cm) from surface is required

Surface Mounting

1. Attach template provided to mounting surface. Make certain it is level.
2. Drill four 5/64" (2 mm) holes.
3. Drill 2" (50 mm) hole with hole saw.
4. Install gasket on back plate.
5. Connect cable (See Wiring).
6. Secure back plate to surface using #4 x 1/2" screws (4).
7. Attach bezel to back plate.

Receptacle Box Mounting

1. Cut out surface the size of receptacle box.
2. Mount receptacle box.
3. Install gasket on back plate.
4. Connect cable (See Wiring).
5. Secure back plate to receptacle using #6-32 x 7/8" screws (2).
6. Attach bezel to back plate.

Control Unit Mounting

1. Locate in an accessible area
2. Secure to wall with proper fasteners using the mounting holes as indicated.

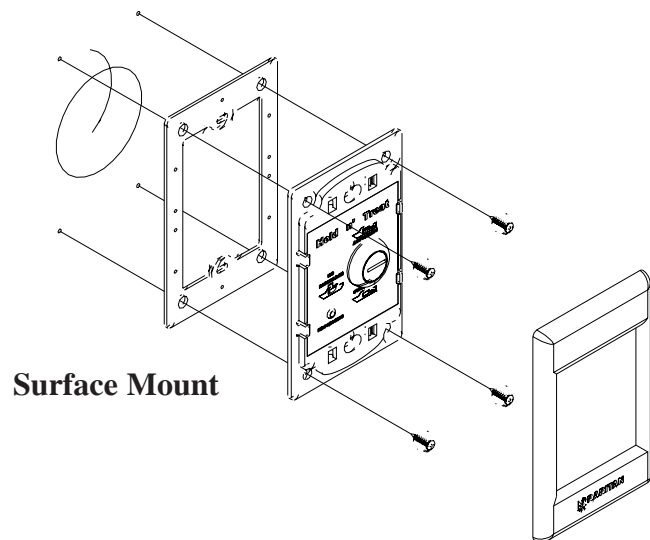
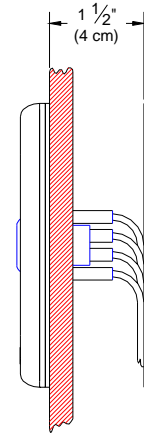

Surface Mount

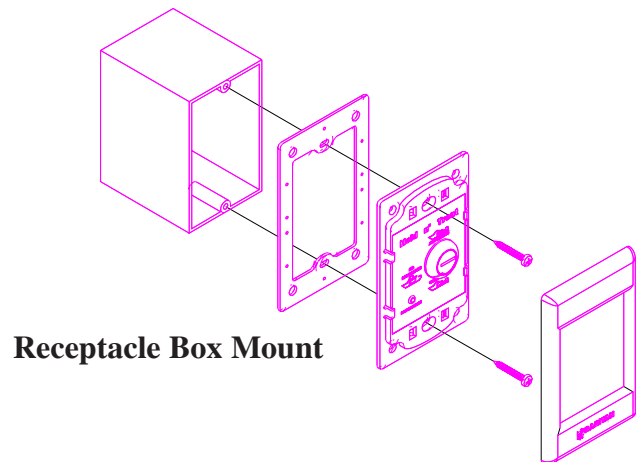

Receptacle Box Mount

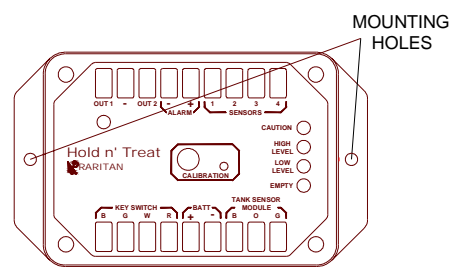

CONTROL UNIT

Mounting the Tank Sensor Modules

NOTE: This product is designed for plastic, fiberglass or fiberglassed wood tanks.

The aluminum foil tape strips must be at least 1" (2.5cm) from any large metal objects, such as, framework, siding, stored items, etc. and located on the side of the tank.

1. Measure distance "X" as indicated by Fig. where the Tank Sensor Modules will be mounted.
2. Cut *two* strips of aluminum foil tape (supplied) 1" (2.5cm) less than distance "X".
3. Calculate the area of *each* aluminum foil tape strip by multiplying the length x width of each strip.

The aluminum foil tape supplied is 2" (5.1cm) wide.

Each aluminum foil tape strip should be between 15 and 40 square inches (97 and 258 square centimeters).

If the area is between 15 and 40 square inches (97 and 258cm square), go to step 4.

If the area is less than 15 square inches (97cm square), the width of each aluminum foil tape strip must be increased. Cut two more lengths of aluminum foil tape the same length as the first two. How to install them will be explained later.

If the area is more than 40 square inches (258cm square), decrease the width of the original aluminum foil tape strip by trimming.

IMPORTANT: Do not adjust the length (height) of aluminum foil tape strip when increasing or decreasing the *area* of the original aluminum foil tape strip.

EXAMPLE: "X" = 11"

11" (27.9cm) minus 1" (2.5cm) = 10" (25.4cm)
(Length of aluminum foil tape strip)

10" (25.4cm) multiplied by 2" (5.1cm) = 20 square inches (129cm square)

4. Clean area thoroughly with isopropyl alcohol.

NOTE: For tanks that have a rough surface; smooth surface by sanding carefully before cleaning. A thin coating of contact adhesive may have to be applied.

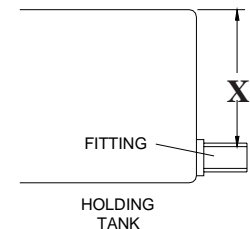
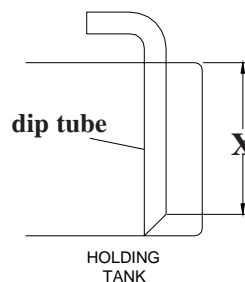

INSTALLATION

IMPORTANT: If using contact adhesive, be certain there is adequate ventilation and adhesive will not damage tank.

5. Remove paper backing from aluminum foil tape strips.
6. Place two aluminum foil tape strips vertically on tank surface, 1/2" (1.27cm) from top and bottom of tank. Aluminum foil tape strips are to be parallel 2" (5cm) to 4" (10cm) apart.

For aluminum foil tape strips, that are less than 15 square inches [97 cm square] (from step 3).

Divide minimum area (15 square inches [97 cm square]) by the length of the aluminum foil tape strip. This is the minimum width that the installed overlapping aluminum foil tape strips need to be.

Example: 15" (38 cm) divided by 6" (15 cm) = 2 1/2" (6.4 cm) minimum width of the two overlapping aluminum foil tape strips.

Place the second aluminum foil tape strips overlapping the first aluminum foil tape strips to at least minimum width.

7. Remove paper backing from tank sensor module and place between the two aluminum foil tape strips. The tank sensor module may be placed anywhere between the aluminum foil tape strips.
8. Remove paper backing from copper pads and place one on each aluminum foil tape strip.

Trim copper pads accordingly if they are *wider* than the aluminum foil tape strips.

Place copper pads over the exposed seam if two aluminum foil tape strips are overlapped.

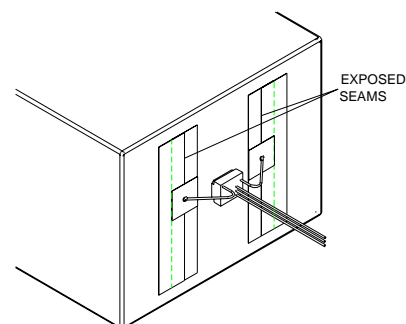
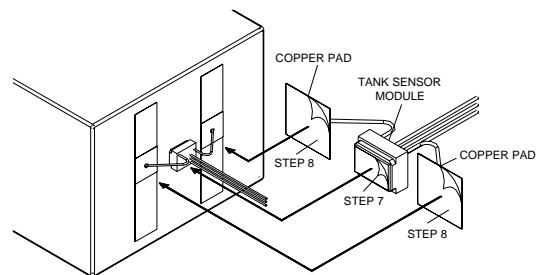
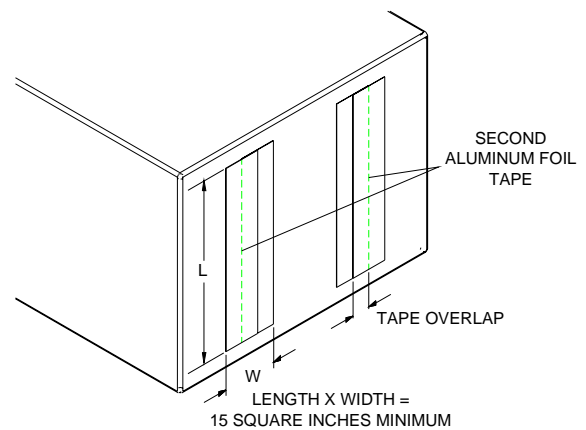
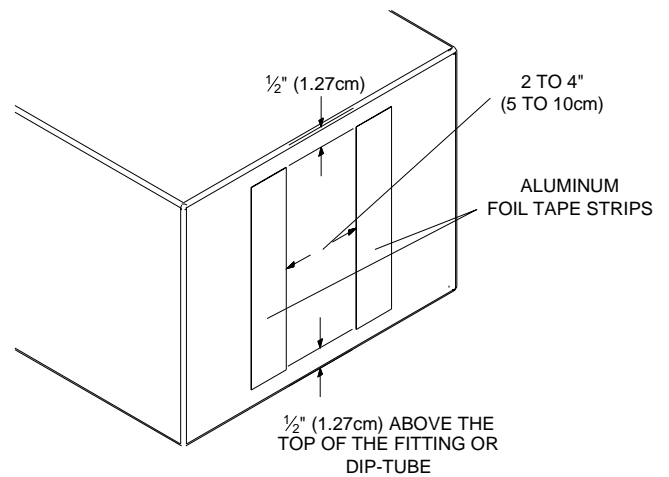

Mounting the Macerator Pump Relay

- Choose a location that accessible and near macerator pump
- Do not locate in an area exposed to weather or splashing water.

Note: Mounting screw not provided (Use 1/4" screw or similar, depending upon mounting surface)

1. Using Relay as template, Mark mounting holes.
2. Drill to proper size (depending on type of screws used)
3. Secure Relay to mounting surface.

Mounting the Macerator Pump

Note: If you currently have a macerator pump installed it may be used.

Refer to the installation instructions provided with the pump

Note: Macerator pump should be mounted at the same level or higher than the holding tank.

PLUMBING

Important:

- **Mount the Lectra/San MC or Purasan within six feet (1.5 meters) of holding tank**

Below is a typical plumbing diagram.

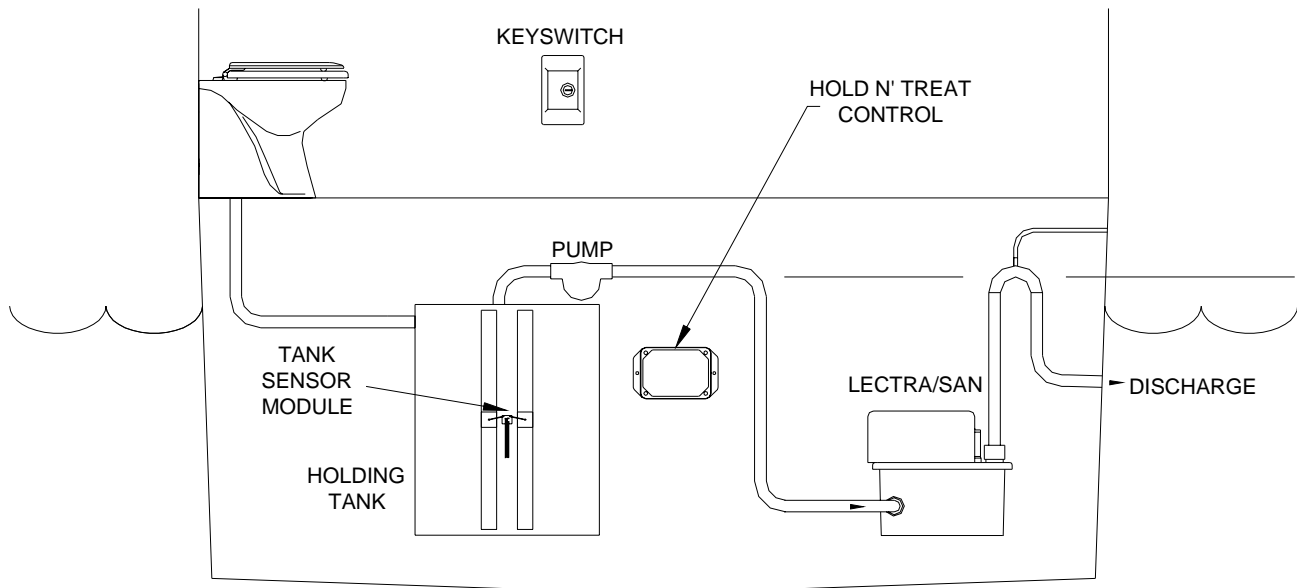

Important

- Do Not Connect wire from OUT 1 (OUT 2) to Lectra/San MC or Purasan until after calibration has been completed.
- Refer to macerator pump for wire and fuse type size.
- All other wiring may be 18 AWG if using multiple conductors with outer sheathing. For single conductors use 16 AWG minimum.

Control Unit must be wired to following components of the system:

- Key switch panel
- Tank level sensor (existing or the sensor supplied with unit)
- Lectra/san or Purasan control board
- Battery positive and negative supply
- Macerator pump relay also needs to be wired to Lectra/san or Purasan control board.

Wiring of Control unit to tank sensor:

1. Using 3 wire 18 AWG cable or 16 AWG WIRES connect green, orange and black wires from sensor module to control unit terminals marked “Tank sensor module”. Each terminal is identified as B(black) O(orange) and G(green). Use ¼” male quick connect terminals at control unit and in-line connectors at sensor module.
2. Secure wires to avoid stress on the quick connect terminals.

(OPTIONAL) Wiring of control unit with existing or float type sensors:

Use this option if your holding tank already has a level sensor system or if tank is metal with float sensor.

1. Determine if existing sensors switch ground wire or positive wire. If sensor give a positive (12V) signal when level has reached it is considered switching positive. If a sensor changes from positive (12V) to ground when level is reached it is considered switching negative.

Note: some level sensors use combination, e.g. low level may switch positive and middle (half) level may switch negative.

**SEE WIRING
DIAGRAM
PAGE 11**

2. Connect 2 wire 18 AWG cable or 16 AWG wires from level sensors to control unit at the terminal marked sensors .Use terminal 1 & 2 for positive switching sensors and terminal 3&4 for ground switching sensor. IF your tank has Low, Mid and high level sensor, use only low and mid level sensors.
3. Use ¼” quick connects at the control unit to connect wires from sensors. Secure wire such that there is no stress on the terminals.

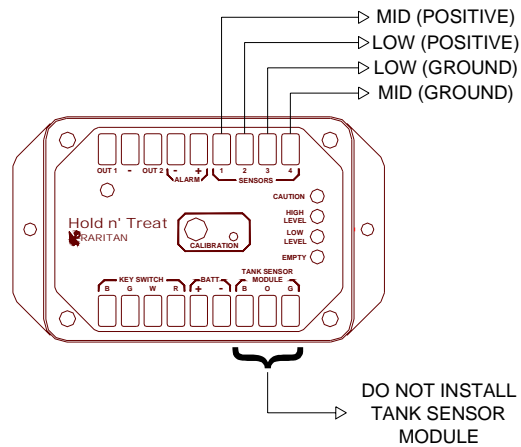

Wiring of control unit to LECTRA/SAN and PURASAN:

1. Use ¼” quick connect and 16 AWG wire to connect terminal marked out1 to Lectra/san control board “EXT TRIG” terminal. LECTRA/SAN control board is located on the treatment tank of the LECTRA/SAN control under the blue cover.
2. Use ¼” quick connect and 16AWG wire to connect terminal marked out1 PURASAN control board “S6” terminal. PURASAN control board is located on the treatment tank of the PURASAN.
3. IF using second treatment system use “out2” terminal on control unit to make connection as above
4. **Disconnect this wire until calibration is completed, after calibration reconnect.**

Wiring the key switch to control unit:

1. Terminals on the key switch and control box are marked B, G, W and R. Connect both end using a cable (18 AWG) or wires (16 AWG).
2. Secure wires near control and the key switch.

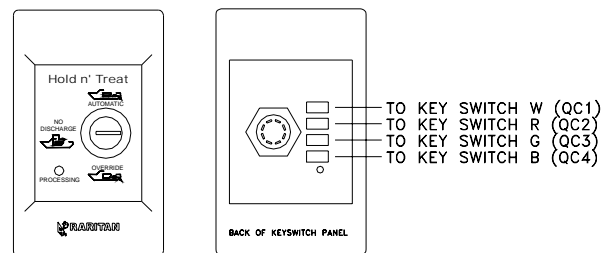

Wiring the MACERATOR pump:

1. Raritan Macerator pump is supplied with the instruction manual for fuses size and wire sizes. IF using other pump refer to manufacturer’s recommendations for wire sizes and fuse/breaker size.
2. Connect positive from battery to the relay and from relay to the pump. Connect NEG from battery directly to pump.
3. Connect relay coil connections (2) to LECTRA/SAN control board’s AUX OUT terminals.
4. For PURASAN use figure at right for wiring the pump.

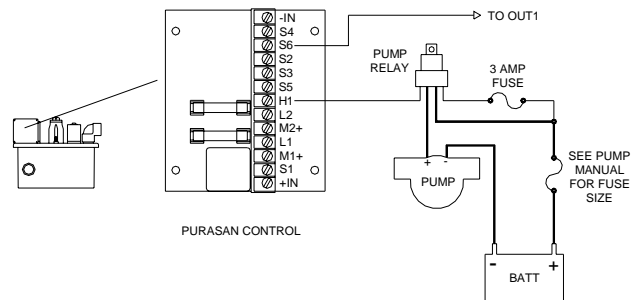

Wiring control unit to Battery:

DO NOT CONNECT POSITIVE UNTIL YOU HAVE CHECKED ALL OTHER WIRING AND ARE READY TO DO CALIBRATION

1. For Power connection use 16 AWG wire from battery positive and NEG to connect to control unit terminal marked as BATT + and — .
2. Install, close to the battery, the provided in-line fuse holder with 5 amp fuse in positive line from battery.

CALIBRATION

Note: a small flat blade screwdriver is needed for calibration.

- Holding Tank should be approximately half to three quarters full to calibrate “Hold n’ Treat”
 - Be certain that Lectra/San MC or Purasan is full of water before proceeding (Refer to Lectra/San MC or Purasan Manual)
 - **Metal Tanks:** Only steps 1, 5 and 6 are required. Steps 2, 3 and 4 do not apply.
1. Adjust macerator pump time setting to approximately six seconds. Adjustment is located on rear of Lectra/San MC Control Indicator Panel. (Lectra/San MC Only)

Note: Purasan, there is no adjustment.

2. Place Keyswitch in AUTOMATIC Position.
3. Press Red Calibration Button and hold.
4. With Red Calibration Button pressed place flat blade screwdriver in small hole next to Red Button and turn until CAUTION Light is just on (Just past point where CAUTION Light is flickering).

Note: calibration pot is a 22 turn pot it may take several complete turns of the screwdriver to make adjustment.

5. After calibration is complete, place Keyswitch to NO DISCHARGE Position.
6. Make connection between OUT1 and Lectra/San MC Control Board.

The system is now ready to operate. When you place Keyswitch to AUTOMATIC Position Lectra/San MC or Purasan should activate within one second. Waste macerator pump should also turn on.

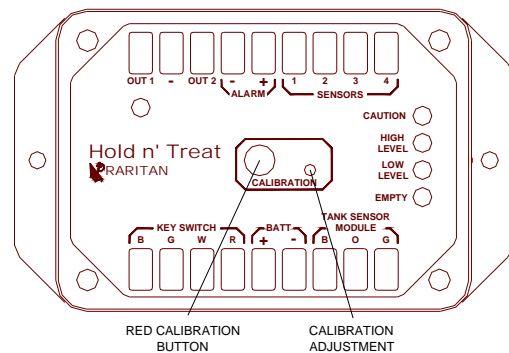

WIRING

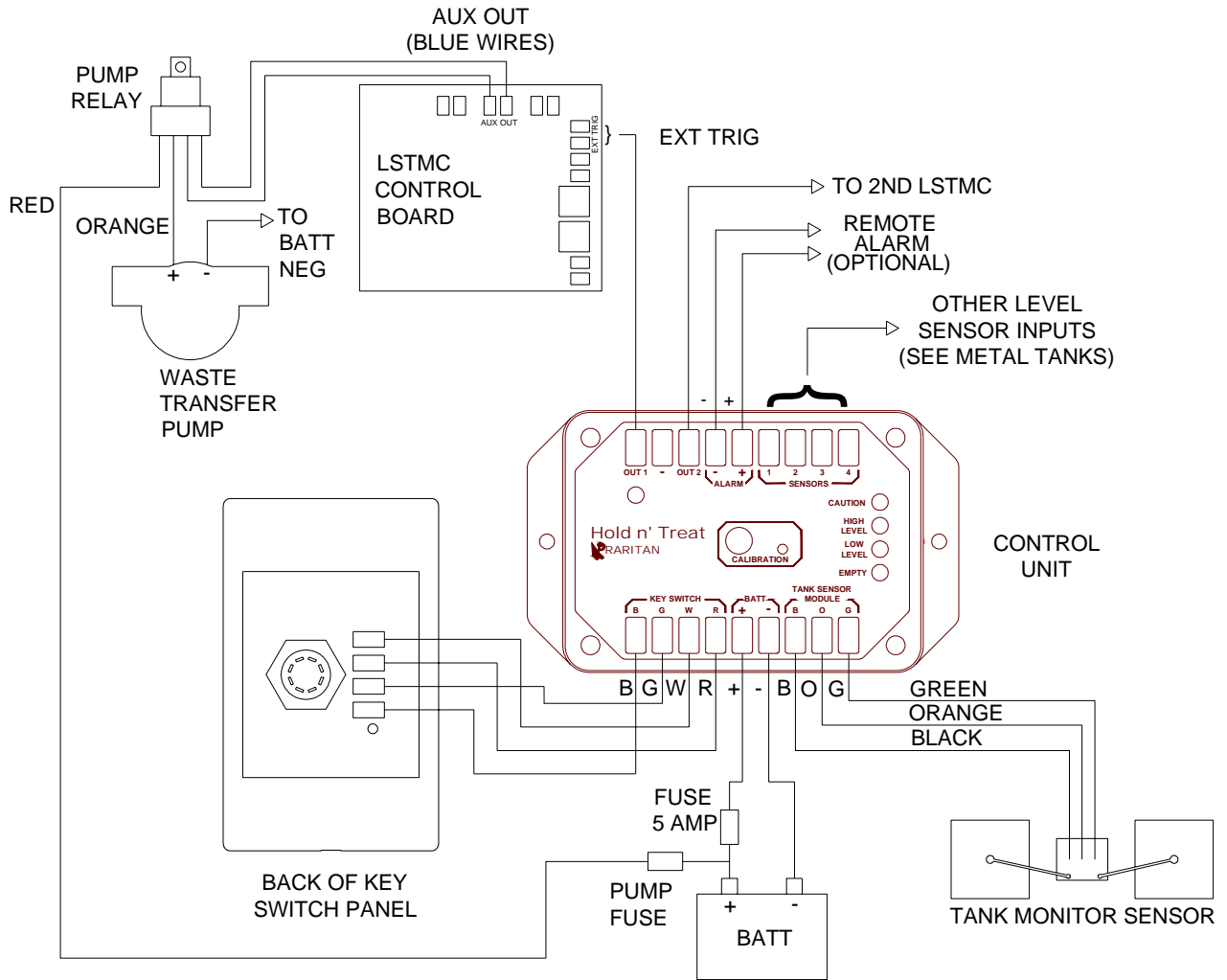

LIMITED WARRANTY

Raritan Engineering Company warrants to the original purchaser that this product is free of defects in materials or workmanship for a period of one year from the product's date of purchase. Should this product prove defective by reason of improper workmanship and/or materials within the warranty period, Raritan shall, at its sole option, repair or replace the product.

1. TO OBTAIN WARRANTY SERVICE, Consumer must deliver the product prepaid, together with a detailed description of the problem, to Raritan at 530 Orange St., Millville, N.J. 08332, or 3101 SW 2nd Ave. Ft. Lauderdale, FL 33315. When requesting warranty service, purchaser must present a sales slip or other document which establishes proof of purchase. **THE RETURN OF THE OWNER REGISTRATION CARD IS NOT A CONDITION PRECEDENT OF WARRANTY COVERAGE.** However, please complete and return the owner Registration Card so that Raritan can contact you should a question of safety arise which could affect you.
2. **THIS WARRANTY DOES NOT COVER** defects caused by modifications, alterations, repairs or service of this product by anyone other than Raritan; defects in materials or workmanship supplied by others in the process of installation of this product; defects caused by installation of this product other than in accordance with the manufacturer's recommended installation instructions or standard industry procedures; physical abuse to, or misuse of, this product. This warranty also does not cover damages to equipment caused by fire, flood, external water, excessive corrosion or Act of God.
3. **ANY EXPRESS WARRANTY NOT PROVIDED HEREIN, AND ANY REMEDY FOR BREACH OF CONTRACT WHICH BUT FOR THIS PROVISION MIGHT ARISE BY IMPLICATION OR OPERATION OF LAW, IS HEREBY EXCLUDED AND DISCLAIMED.** ALL IMPLIED WARRANTIES SUCH AS THOSE OF MERCHANTABILITY AND OF FITNESS FOR A PARTICULAR PURPOSE, IF APPLICABLE, AS WELL AS ANY IMPLIED WARRANTIES WHICH MIGHT ARISE BY IMPLICATION OF LAW, ARE EXPRESSLY LIMITED TO A TERM OF ONE YEAR. SOME STATES DO NOT ALLOW LIMITATIONS ON HOW LONG A LIMITED WARRANTY LASTS, SO THE ABOVE LIMITATION MAY NOT APPLY TO YOU.
4. **UNDER NO CIRCUMSTANCES SHALL RARITAN BE LIABLE TO PURCHASER OR ANY OTHER PERSONS FOR ANY SPECIAL OR CONSEQUENTIAL DAMAGES, WHETHER ARISING OUT OF BREACH OF WARRANTY, BREACH OF CONTRACT, OR OTHERWISE.** SOME STATES DO NOT ALLOW THE EXCLUSION OR LIMITATION OF INCIDENTAL OR CONSEQUENTIAL DAMAGES, SO THE ABOVE LIMITATION OR EXCLUSION MAY NOT APPLY TO YOU.
5. No other person or entity is authorized to make any express warranty, promise or affirmation of fact or to assume any other liability on behalf of Raritan in connection with its products except as specifically set forth in this warranty.
6. This warranty gives you specific legal rights, and you may also have other rights which vary from state to state.



530 Orange Street, P.O. Box 1157, Millville, NJ 08332 USA
Telephone: 856-825-4900 FAX: 856-825-4409
www.raritaneng.com
Southern Office and Plant:
3101 SW Second Avenue, Fort Lauderdale, FL 33315 USA
Telephone: 954-525-0378 FAX: 954-764-4370