

ATLANTES™

Household Style Marine Toilet - Water Saver Feature Model (Model A5 and A6)

THE FOLLOWING ARE CAUTIONARY STATEMENTS THAT MUST BE READ AND FOLLOWED DURING BOTH INSTALLATION AND OPERATION

WARNING: *Raritan Engineering Company, Inc. recommends that a qualified person or electrician install this product. Equipment damage, injury to personnel or death could result from improper installation. Raritan Engineering Company, Inc. accepts no responsibility or liability for damage to equipment, or injury or death to personnel that may result from improper installation or operation of this product.*

WARNING: **HAZARD OF FLOODING**-Always shut off seacocks before leaving the boat unattended. Double clamp all below waterline hose fittings and check frequently for integrity.

HAZARD OF SHOCK OR FIRE-Always use recommended fuse, circuit breaker and wire size.

CAUTION - Do not flush anything except water, human waste, Raritan Concentrate and toilet tissue through this toilet.

INTRODUCTION

The Atlantes toilet has been designed to allow all working parts to fit inside the one-piece porcelain bowl. The powerful centrifugal macerating pump thoroughly breaks down waste in preparation for treatment or holding. Three systems are available:

1. **Internal intake pump** - for above waterline installations only.
2. **Remote mounted intake pump** - for above and below waterline installations.
3. **Freshwater solenoid valve** - for flushing with pressurized fresh water.

IMPORTANT: Pressurized water source must provide a minimum flow rate of 3 gallons (11.3 liters) per minute at a minimum pressure of 5 psi (34.5 kPa).

OPERATION

Flush Lever (A5 Models) - See Fig. #2A

- A. Normal Flush:** Gently push the flush lever downward and release. This starts an automatic timed flush which starts the intake pump first to wet the bowl. After two seconds the discharge pump will start and flushes the bowl. The intake pump will continue to run for a few more seconds after the discharge pump stops if the jumper is set to retain water in the bowl. See Fig. #3A on page 2 and "Increasing Bowl Water Level" on page 7. If wired as per Fig. #4 the Lectra/San will start.

CAUTION: If rinse water does not flow from the rim after the first flush cycle, discontinue use of toilet and refer to Troubleshooting. Running the pump dry for extended periods will cause damage to the pump.

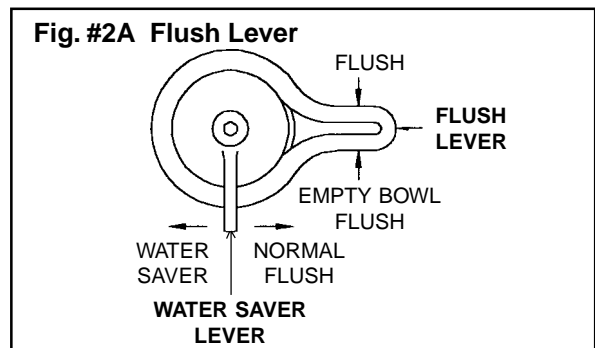
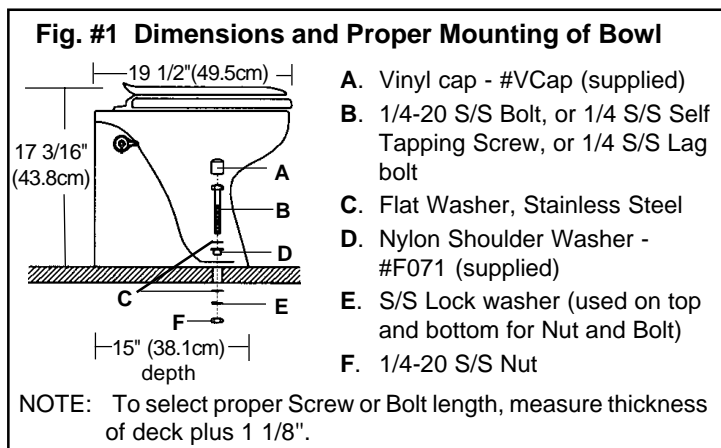
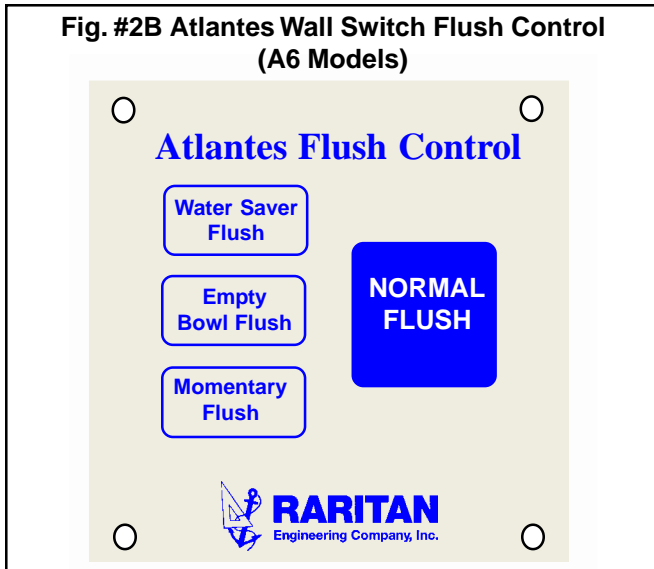

Fig. #2B Atlantes Wall Switch Flush Control (A6 Models)



B. Water Saver Mode: Normal flush time can be reduced by approximately one half by moving water saver lever back. The normal flush time can be restored by moving water saver lever forward to normal flush (see Fig. #2A). If wired as per Fig. #4 the Lectra/San will start.

C. Empty Bowl: Pulling flush lever upward and holding it evacuates the bowl without bringing in additional water.

Stopping a Timed Flush: A timed flush can be stopped by pulling the flush lever upward momentarily. If the Lectra/San has been started it will NOT be stopped.

**Wall Switch Flush Control (A6 Models)
See Fig. #2B**

A. Normal Flush: Press “Normal Flush” touch pad to start a normal flush. Intake pump starts first to wet the bowl. After two seconds the discharge pump will start and flushes the bowl. Both pumps stop after ten to sixteen seconds, determined by the jumper settings (refer to Fig. #5). The intake pump will continue to run for a few more seconds after the discharge pump stops if the jumper is set to retain water in the bowl (refer to Increasing Bowl Water Level on page 7). If wired as per Fig. #4 the Lectra/San will start.

CAUTION: If rinse water does not flow from the rim after the first flush cycle, discontinue use of toilet and refer to Troubleshooting. Running the pump dry for extended periods will cause damage to the pump.

B. Water Saver: Press “Water Saver Flush” touch pad once to start a water saver flush. Both pumps

Fig. # 3A (A5 Models)

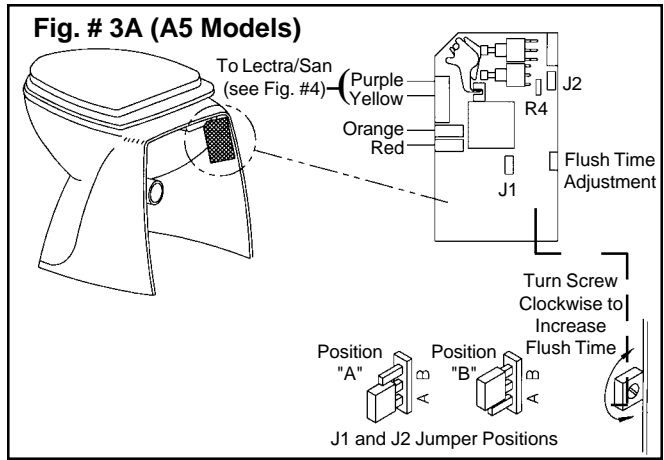
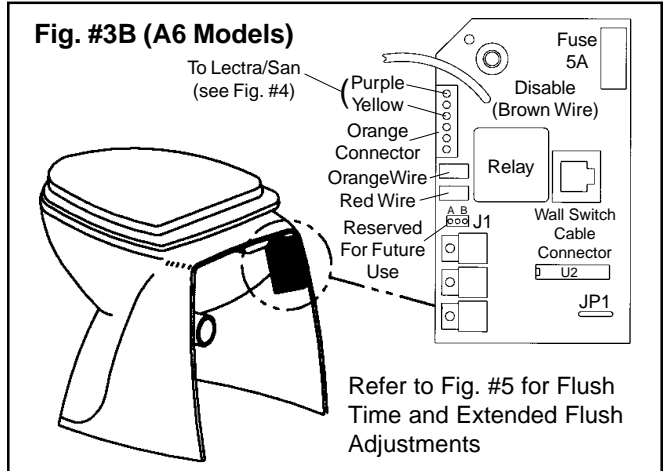

Fig. #3B (A6 Models)



will start and water saver flush will run for half of the time determined by the jumper setting (see Fig. #5). If wired as per Fig. #4 the Lectra/San will start.

C. Empty Bowl: Press and hold “Empty Bowl Flush” touch pad to evacuate the bowl without bring in additional water. If wired as per Fig. #4 the Lectra/San will NOT start.

D. Momentary Flush: Press and hold “Momentary Flush” touch pad to flush bowl momentarily. Both pumps will run as long as this touch pad is pressed. If wired as per Fig. # 4 the Lectra/San will start.

Stopping a Timed Flush: A timed flush can be stopped by pressing any one of the four touch pads momentarily once. If the Lectra/San has been started it will NOT be stopped by this feature.

If Lectra/San is activating Atlantes: The Atlantes control remembers which of the two timed flush touch pads was pressed last (“Normal Flush” and “Water Saver Flush”) and runs in that mode when it is activated by the Lectra/San. The Atlantes will run in a normal flush cycle if no touch pads were pressed after the power was turned on. To activate the

Fig. #4 Activation of LST/EC or LST/MC from an Atlantes Toilet

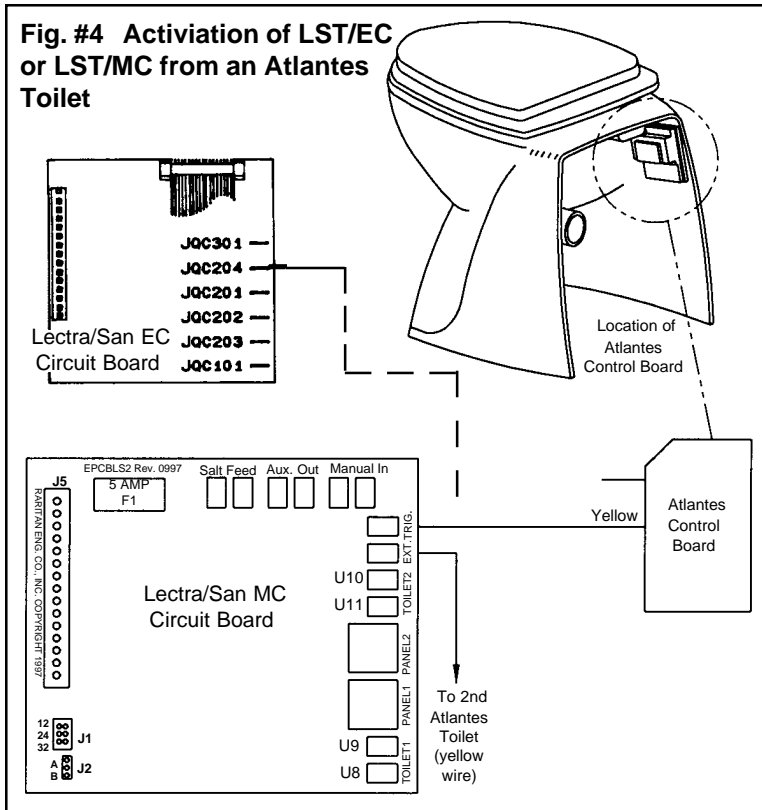

Atlantes from the Lectra/San in a water saver flush mode every time, press “Water Saver Flush” touch pad once. To return to a normal flush mode press “Normal Flush” touch pad once.

Disable Atlantes Activation - A6 Models only: If supply voltage is provided on disable input (see Fig. #3B) line (brown wire), then the Atlantes will NOT activate any flush. If a flush cycle is already in progress when supply voltage appears at disable input, then flush cycle will be aborted. Contact Technical Support for specific applications.

MAINTENANCE

Periodically inspect the base of the toilet and the hose connections for leaks. Inspect wire terminals and connections for corrosion semi-annually.

Fig. #5 J1 Jumper Settings for Wall Switch Flush Control Models

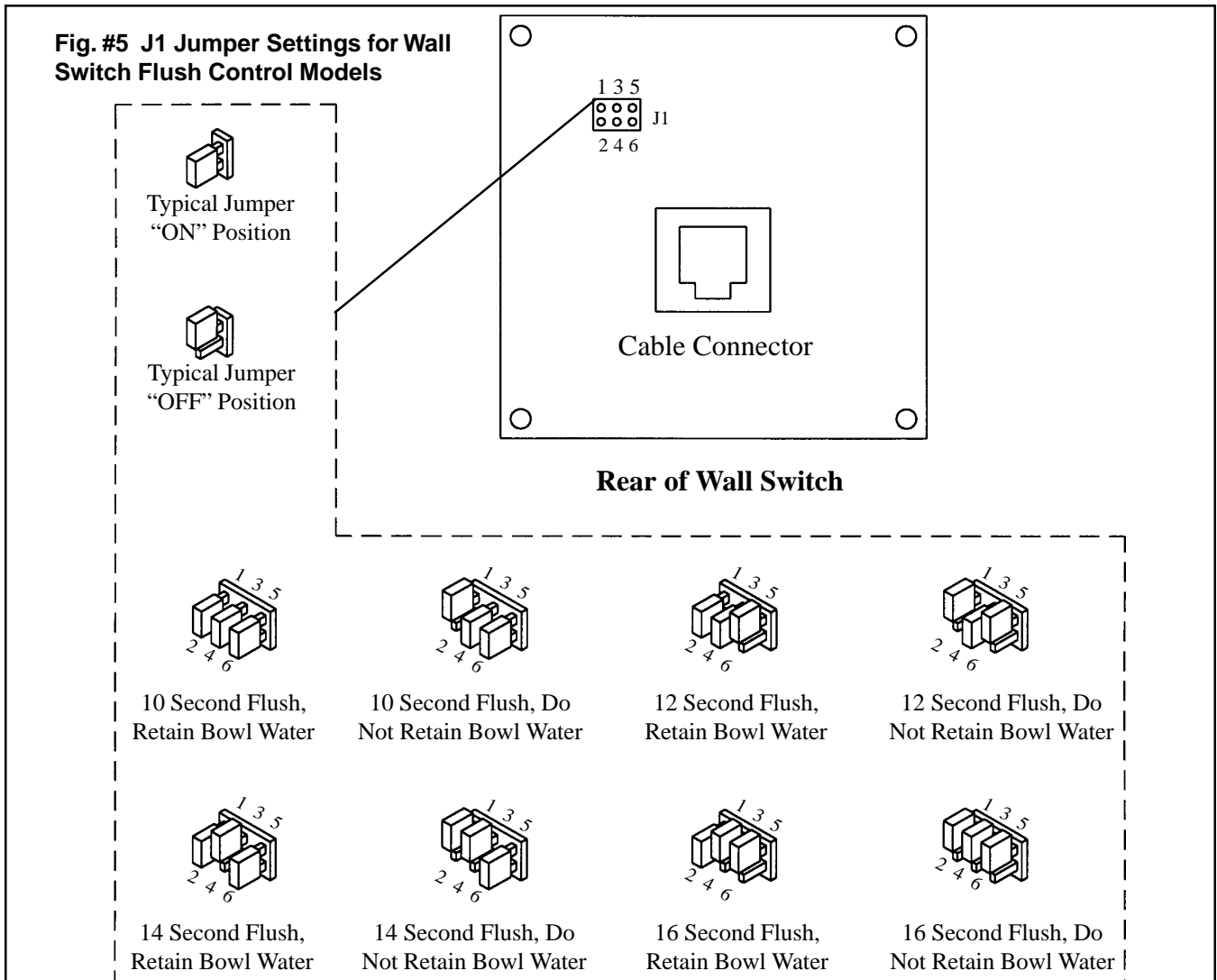

Fig. #6 Atlantes with remote intake pump, installed with a Lectra/San® Type I MSD (in sea water). Below waterline shown.

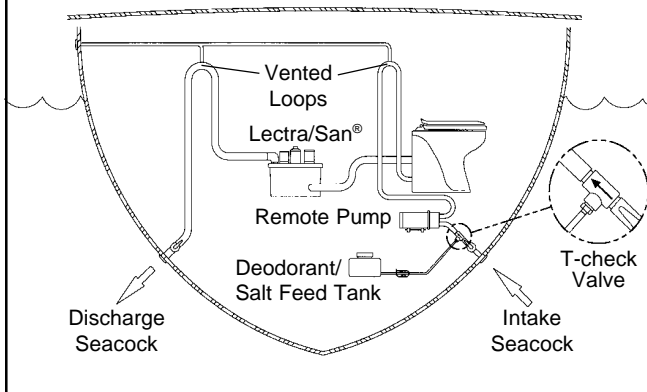

Fig. #7 Atlantes with integral pump, deodorant/salt feed tank installed (in fresh or brackish). Above waterline shown.

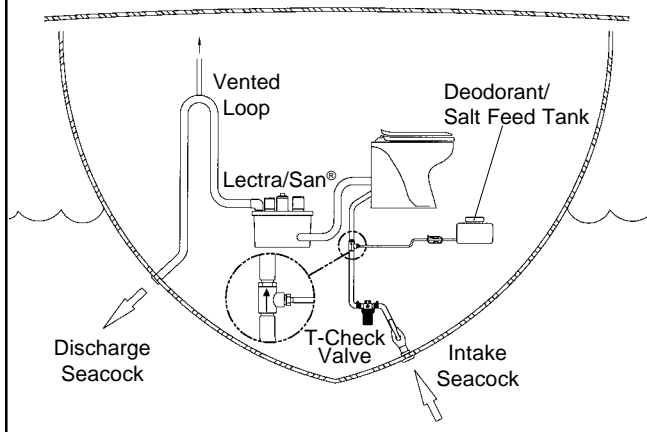

Fig. #8 Atlantes with Water Solenoid valve (part #'s: A5F* or A5AF*) for water system connection with holding tank.

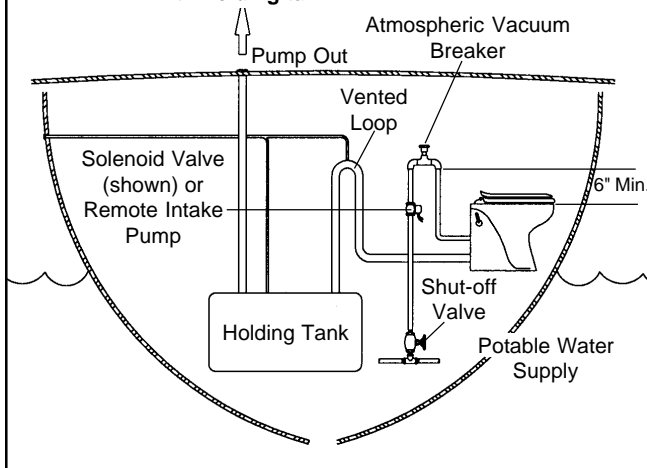
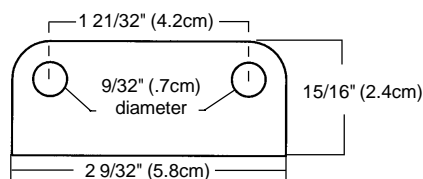

Fig. #8A Solenoid valve dimensions



Cleaning:

- Using C.P. (#1PCP22), a bio-enzymatic toilet bowl cleaner (available from Raritan Engineering), will keep the bowl clean and fresh smelling. **DO NOT USE any chemicals that contain ammonia, ethyl acetate, phosphoric acid and concentrated chlorine bleach;** they will damage internal parts.
- Units with Deodorant/Salt Feed Tank should use Raritan Concentrate (#CON22) to help keep the bowl clean and lubricate the internal working parts.

WINTERIZING

IMPORTANT: To prevent damage from freezing, the following steps must be taken.

- Close intake and discharge seacock and leave closed until recommissioning boat.
- Disconnect and drain all intake and discharge hoses. (TIP: Have two small containers handy to collect excess water.)

CAUTION: Use only non-toxic antifreeze.

3A. Atlantes with intake pumps: Attach a separate piece of hose to both intake and discharge fittings of toilet. Pour one quart (1 liter) of non-toxic antifreeze into one of the containers. Place short intake hose in this container. Place empty container under discharge. To ensure antifreeze has circulated through the entire toilet, flush until antifreeze is discharged into empty container. Pouring antifreeze into bowl will only protect discharge pump.

3B. Atlantes with pressurized intake water sources: Place empty container under discharge. Pour antifreeze into bowl. Flush Lever toilets: Flush toilet by pulling flush lever up until antifreeze has been purged from unit. Wall Switch Flush Control toilets: Flush toilet by pressing the "Empty Bowl Flush" touch pad. Repeat if necessary.

NOTE: Antifreeze should remain in the toilet until recommissioning.

Fig. #9

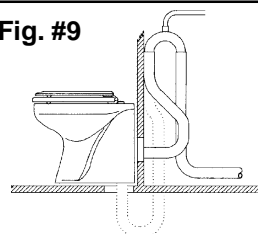

Hoses may be routed through floor or wall.

Fig. #10

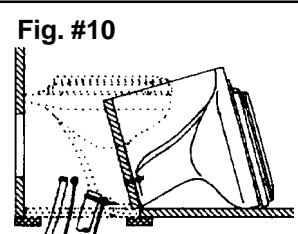

Installing on hinged board.

RECOMMISSIONING

IMPORTANT: Properly dispose of antifreeze.

1A. **Atlantes with intake pumps:** Place short intake line in a bucket of water; place a container under the discharge. Run toilet until all antifreeze has been discharged.

1B. **Atlantes with pressurized intake water source:** Place clean water into bowl. Flush toilet by pulling flush lever up (in Flush Lever toilets) or pressing the "Empty Bowl Flush" touch pad (in Wall Switch Flush Control toilets) until antifreeze has been purged from unit. Repeat if necessary.

2. Reconnect intake and discharge lines. Open seacocks and run toilet through one flush cycle.

Template on Reverse Side

SYSTEM COMPONENTS

All Atlantes include: seat and cover, necessary mounting hardware and an owner's manual. Depending on the model you order, some include Atlantes Deodorant System (#ADS), straight discharge, water solenoid or remote intake pump. Atlantes Deodorant/Salt Feed Tank is not included in Fresh Water Solenoid models. Included with the A5 Models is a 3/32" Allen wrench. A6 Models include Atlantes Wall Switch Flush Control Panel and cable.

INSTALLATION

Materials required: A drill with a 3/16", 5/64" and a 9/32" drill bit, two 1/4" diameter stainless steel fasteners (lag screws or machine screws with washers and lock washers), jig saw, blade screwdriver, 1 1/2" (38mm) ID sanitation hose, 3/4" (19mm) ID reinforced intake hose with fittings and clamps, wiring, fuses or breakers (see specification tables).

Before starting installation please be sure that you have received the model ordered. Figs. #6 through #10 show basic installation options. Should you have a question please contact Technical Support at Millville, NJ or Ft. Lauderdale, FL.

Changing Flush Time in Flush Lever Toilets (A5 Models): The normal flush is factory pre-set for approximately 10 seconds. Installations that require longer flush times can be changed by carefully rotating the position of the potentiometer clockwise (see Fig. #3A). Maximum rotation (270°) will approximately double the length of time. Waste moves about one foot per second in 1 1/2" (38mm) lines. Increasing flush time will also increase the amount of water used during both normal and water saver flushing.

Changing Flush Time in Wall Switch Flush Control Toilets (A6 Models): Normal flush can be set to flush for 10, 12, 14 or 16 seconds by setting jumpers (3-4, 5-6) located behind the touch pad panel. See Fig. #5 for chart and setting. Water Saver Flush will be half of the time set by these jumpers.

MOUNTING

A. Normal Mounting

1. Position the bowl on a flat solid deck. Using a pencil, mark locations of bowl mounting bolt holes and trace around one side of the bowl. If hoses will be routed through wall, also trace one side of the bowl from floor to top of bowl while against the wall. Cut necessary holes using enclosed template through wall or floor.
2. Attach Seat and Cover.
3. Secure bowl to deck using stainless steel bolts (see Fig. #1) after all plumbing and electrical connections have been made, the unit has been tested for proper operation and checked for leaks.

CAUTION: Damage to bowl may occur if not properly secured. Tighten both mounting bolts simultaneously, DO NOT overtighten.

B. Optional Mounting

To install per Fig. #10. Cut out a 15" (38cm) x 15" (38cm) opening, install support cleats below the opening, attach hinges to deck and cut-out, bolt the bowl to the hinged cut-out, and secure board with thumb screws.

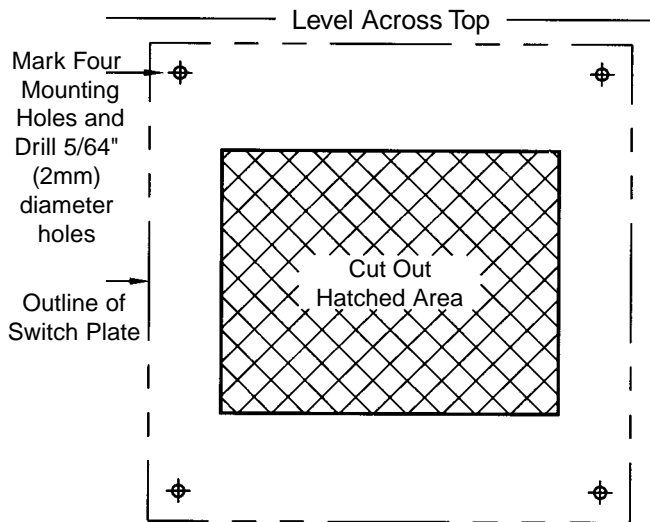

Mounting Template for Atlantis Wall Switch Flush Control Panel

Mounting Wall Switch (A6 Models)

1. Prepare the wall switch mounting area using the mounting template provided.
2. Route the cable from the Atlantis Control Assembly to the opening on the wall and attach it to the back of the Atlantis Wall Switch Flush Control Panel (#AMW603). Secure cable every 18 inches (45.7cm). Do not damage insulation.
3. The jumpers are preset at the factory for a normal ten second flush cycle. For a longer flush cycle configure the jumpers on the back of the Wall Switch Flush Control Panel (see Fig. #5, page 3).
4. Secure Atlantis Wall Switch Flush Control Panel into position using four screws provided. If located in shower/head compartment, apply a bead of nonpermanent sealant around rear edges of the faceplate before securing.

PLUMBING

WARNING: Below waterline installations require vented loops. The top of the loop must be above the waterline at greatest angle of heel. Intake vented loops must be installed between the pump and the back of the bowl. Discharge vented loops must be installed between the discharge of the toilet and the seacock.

All installations should have approximately eight to ten inches (20.3 cm - 25.4 cm) of slack in plumbing

and electrical lines to allow for easy access. This can be done as shown in Fig. #9 or by installing the toilet on a separate hinged board (Fig. #10). Use of an In-Line Strainer (#163000) is required to prevent marine vegetation and debris from damaging the system.

INTAKE INSTALLATIONS

A. Integral Intake Pump: Attach a 3/4" (19mm) reinforced suction hose from seacock or nonpressurized water source to the T-check valve (connected to intake pump).

NOTE: Deodorant tank attaches to T-check valve (if used). Nipple must remain capped if not used.

B. Pressurized Freshwater Installations:

WARNING: HAZARD OF POTABLE WATER CONTAMINATION. A back flow prevention device must be used with any installation using a potable water source.

IMPORTANT: Pressurized water source must provide a minimum flow rate of 3 gallons (11.3 liters) per minute at a minimum pressure of 5 psi (34.5 kPa).

A shut off valve must be installed before the solenoid valve (#CWPS*). Refer to plumbing layout (Fig. #8).

1. Secure solenoid valve mounting bracket using two 1/4" diameter screws or bolts (Fig. #8A).
2. Attach solenoid valve to bracket.

NOTE: Mount valve according to flow markings on valve body.

3. A back flow prevention device must be installed between the solenoid and the back of the bowl a minimum of six inches (15.2cm) above the toilet.

C. Remote Intake Pump Installation:

WARNING: DO NOT USE deodorant system (ADS) if installed using a potable water source.

1. Mount remote pump to a deck or bulkhead.
2. Attach 3/4" (19mm) intake hose from seacock or non-pressurized water source to **suction** side of intake pump.
3. Install the T-check valve in the hose installed in Step #2 between the water source and the pump.

* Specify Voltage

Fig. #11A Wiring Diagram for Atlantes DC Units with Internal Intake Pump

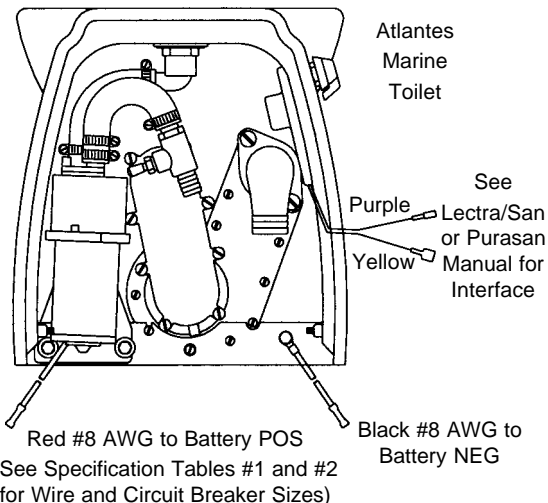
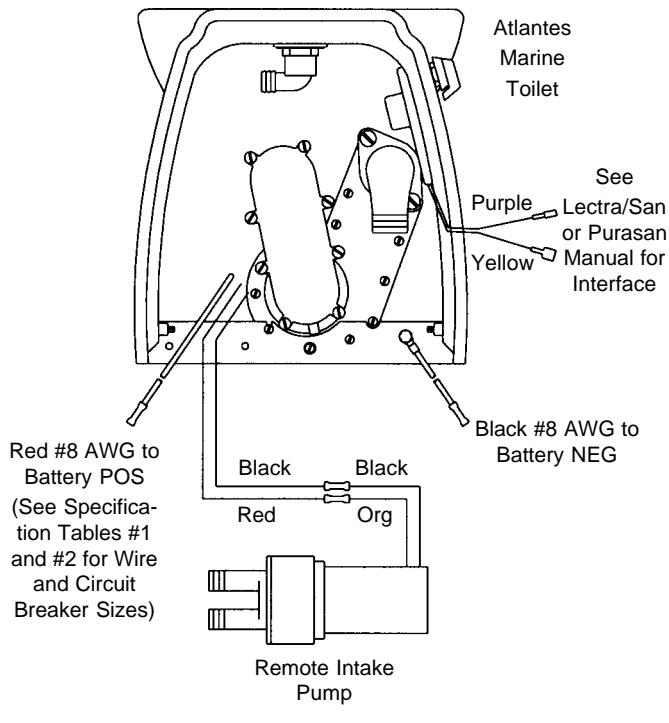

Fig. #11B Wiring Diagram for Atlantes DC Units with Remote Intake Pump



NOTE: Mount valve according to flow markings on valve body.

4. A 3/4" (19mm) hose is then attached to pressure side of pump and connects to the Atlantes at bowl elbow (pump nozzles are marked "suction" and "pressure"). Refer to Fig. #6.

DISCHARGE INSTALLATION:

1. Attach 1 1/2" (38mm) ID quality sanitation hose (#SH) to discharge fitting. Use either attached 90° fitting or optional straight fitting.
2. Discharge hose runs longer than 16 feet (4.9m) should install a vented loop near the toilet to force the waste beyond vented loop to drain by gravity.

Increasing Bowl Water Level:

NOTE: A vented loop in the discharge line will help retain water in the bowl.

Above waterline installations may install an internal vented loop (#AHDA1W - internal vented loop). A 90° discharge fitting must be used with an #AHDA1W.

Flush Lever Toilets (A5 Models): To increase water in the bowl move jumper J1 on control board to position "A". Units with factory installed internal vented loops are preset to position "A" (see Fig. #3A for jumper location). This will cause the inlet pump to continue running for a few more seconds after discharge pump has stopped.

Wall Switch Flush Control Toilets (A6 Models):

To increase water in the bowl set jumper (1-2) to "ON" position. This will cause intake pump to continue running for few more seconds after discharge pump has stopped (see Fig. #5).

Fig. #11C Wiring the Atlantes DC Units with Pressurized Fresh Water

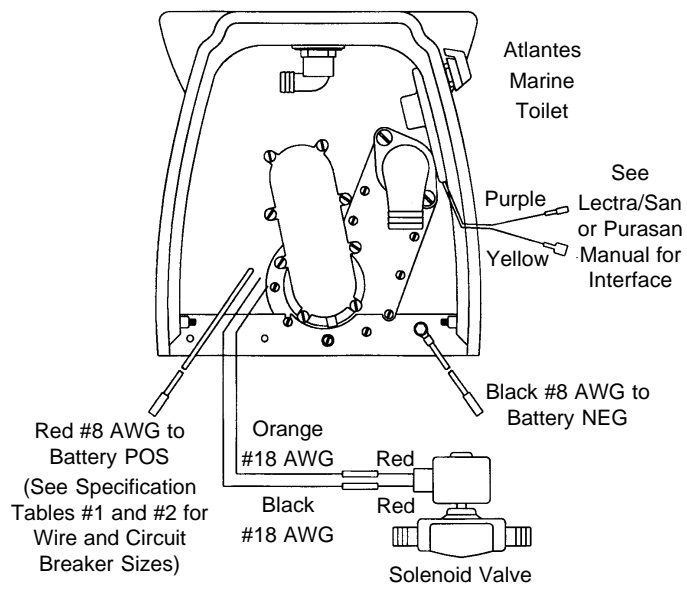

WIRING

WARNING: Hazard of Electrical Shock and Fire.

Using Specification Tables #1 and 2 determine proper wire and circuit breaker/fuse sizes that is appropriate for voltage and amperage of unit.

Measure distance from power source to toilet. To determine proper length of wire add three feet (1 m) to length measured. To determine proper wire gauge, double the length.

For all DC powered Atlantes: Connect black (negative) and red (positive) wires at rear of unit to batteries (see Fig's. 11A, 11B and 11C).

For Atlantes with remote intake pump: Determine proper gauge from Specification Table #1. Connect to the remote intake pump to the wires from the back of the bowl labeled "remote pump". Connect red wire (positive) to orange wire and black wire (negative) to black wire. See Fig. #11B.

For Atlantes with remote water solenoid valve: Connect black and orange 18 ga. wire from back of bowl to water solenoid valve (see Fig. #11C). Polarity is irrelevant.

120/240 VAC Units: For proper wire gage and circuit breaker from Transformer (#RTAH24D) to unit, refer to Specification Table #1 - 24 V DC units. Refer to Installation Instructions included with #RTAH24D.

Specifications - Table #1								
Amperage Draw								
Nominal Voltage of Unit		12V DC			24V DC		32V DC	
Amp Draw of Atlantes								
With Intake Pumps		40			20		16	
With Solenoid Valve		11			5.5		4.5	
Wire Sizes								
Models	Unit's Voltage	Distance from source to unit and back to source [feet (m)]						
		10'(3.1)	15'(4.6)	20'(6.1)	25'(7.2)	30'(9.2)	40'(12.2)	50'(15.2)
Minimum recommended conductor wire AWG (mm ²) for 3% voltage drop								
Remote and Internal Intake Pump	12	8(10.0)	6(16.0)	6(16.0)	4(25.0)	4(25.0)	2(35.0)	2(35.0)
	24	14(2.5)	12(4.0)	10(6.0)	10(6.0)	10(6.0)	8(10.0)	6(16.0)
	32	16(1.5)	14(2.5)	12(4.0)	12(4.0)	10(6.0)	10(6.0)	8(10.0)
Remote Water Solenoid Valve	12	12(4.0)	10(6.0)	10(6.0)	8(10.0)	8(10.0)	6(16.0)	6(16.0)
	24	18(1.0)	16(1.5)	14(2.5)	12(4.0)	12(4.0)	10(6.0)	10(6.0)
	32	18(1.0)	18(1.0)	18(1.0)	18(1.0)	16(1.5)	16(1.5)	14(2.5)
Remote Intake Pump Branch Circuit	12	10(6.0)	8(10.0)	6(16.0)	6(16.0)	4(25.0)	4(25.0)	2(35.0)
	24	16(1.5)	14(2.5)	12(4.0)	12(4.0)	10(6.0)	10(6.0)	8(10.0)
	32	16(1.5)	14(2.5)	14(2.5)	12(4.0)	12(4.0)	10(6.0)	10(6.0)

NOTE: Recommended conductor sizes based on 105°C rated insulation. Refer to ABYC Standards for other insulation ratings.

Specifications - Table #2				
Circuit Breaker/Fuse Sizes				
	12V DC	24V DC	32V DC	
Main Circuit Breaker/Fuse				
Atlantes with Intake Pump	50	30	20	
Atlantes with Solenoid Valve	15	10	10	
Circuit Breaker/fuse included (See figure below)				
Voltage	A and AR Models		AF Models	
	Fuse A	Fuse B	Fuse A	Fuse B
12	AM090A(35A)	AM091(15A)	AM092(4A)	AM091(15A)
24	AM093(20A)	AM094(10A)	AM092(4A)	AM094(10A)
32	34-220(MDL20A)	34-218(MDL5A)	34-218(MDL5A)	34-218(MDL5A)
Maximum Height of Vented Loop			Six (6) feet from floor	
Intake Water Requirement			Six (6) GPM at 5 psi (34.5 kPa)	
For Fresh Water Systems			Measured at Bowl Elbow	
			Minimum 3 gallons per minute with a minimum 5 psi (34.5 kPa)	
			Do Not Exceed 50 psi (345 kPa)	

TROUBLESHOOTING

WARNING: Before beginning any work on the Atlantes be sure that all power to the unit has been turned off and that seacocks are in the CLOSED or OFF position.

Any questions regarding servicing or operation of the Atlantes, contact Technical Support in Millville, NJ or Fort Lauderdale, FL. Please have model and serial numbers of unit before calling.

PROBLEM	CAUSE	CONCLUSION
1. Poor / No water flow from rim of bowl.	1A. Seacock closed. 1B. Air leak in suction line. 1C. Concentrate tank empty. 1D. Intake pump impeller worn. 1E. Intake check valve clogged. 1F. Internal circuit breaker open. 1G. Fresh water solenoid clogged. 1H. Intake strainer clogged. 1I. Faulty circuit board. 1J. Faulty pump motor.	1A. Be sure intake seacock is open. 1B. Check and retighten suction line fittings and clamps. 1C. Refill tank: add 8 oz. (237 ml) concentrate and fill with water. 1D. Inspect impeller and replace if necessary. 1E. Disassemble, clean and reassemble. 1F. Disconnect power from unit for 5 minutes for automatic reset. 1G. Remove solenoid and clean or replace. 1H. Clean strainer. 1I. Replace circuit board (see "Emergency Operation" below). 1J. Repair or replace pump motor.
2. Poor/No discharge out of bowl.	2A. Low voltage. 2B. Restricted discharge line. 2C. Internal circuit breaker open. 2D. Clogged holding tank vent. 2E. Clogged joker valve. 2F. Vented loop valve clogged.	2A. Check voltage at toilet while running. If less than nominal voltage: Check condition of batteries, electrical system and connections (heat at terminals and junctions indicates a bad or corroded connection. Be sure wire gauge is proper size, refer to Table #1. 2B. Be sure seacock is open and discharge line is clear. 2C. Remove power from unit for 5 minutes for automatic reset. 2D. Clean or replace vent. 2E. Clean or replace joker valve. 2F. Clean or replace vented loop valve.
3. Foul odors from head.	3A. Sulphur smell - Marine life lodged in rim of bowl, dark specks. 3B. Sewage smell - loose, leaking or poor quality hose. 3C. Clogged tank or loop vent. 3D. Sewage left in discharge line. 3E. Concentrate not used. 3F. Intake and discharge thru-hull fittings located too close together; recirculating waste water.	3A. Clean bowl and install an In-Line Strainer (#163000) in intake line will help prevent recurrence. 3B. Inspect hose connections for leak. Rub hose with cloth; if cloth "picks up" odor, replace entire discharge hose line with sanitation hose. 3C. Remove vent fittings. Clean, inspect, replace if necessary. 3D. Increase flush time to keep lines clear. 3E. Installing and using Raritan Concentrate (#CON22) will help control odors. 3F. Transfer hose connections such that recirculation will not occur.
4. Loud noises	4A. Hard/solid object in macerator. 4B. Air leak in suction line, check valve or impeller problem.	4A. Inspect macerator thru clear cover. Remove cover, clean if necessary. 4B. See 1A and 1D.
5. Concentrate tank does not empty or overflows.	5A. Flow improperly set. 5B. Jammed check valve.	5A. Adjust clamp. 5B. Remove check valve. Clean, check, replace if necessary.
6. Bowl fills with water.	6A. Joker valve stuck open. 6B. Pressure build-up at seacock while underway. 6C. No external vented loop in discharge line. 6D. Less than 5 psi (34.5 kPa) at solenoid valve.	6A. Remove discharge fitting. Clean joker valve, replacing if necessary. 6B. Close intake, then discharge seacock, to find which one is causing the problem. Insure correct plumbing, install vented loops if necessary. 6C. Install vented loop. 6D. Increase water system pressure to plus 5 psi (34.5 kPa).
7. Bowl does not retain water after flushing.	7A. Poor or low water flow. 7B. No vented loop in discharge line.	7A. See #1 above. 7B. Install internal or external vented loop as needed.

Emergency Operation for A5 Models Only: CAUTION: Disconnect power to unit at source. In the event of certain circuit board failures, the toilet can be flushed by moving Jumper J2 to position "A" and removing R4 (12V- Green Jumper, 24V & 32V- Resistor, both located on circuit board) - see Figure #3A. To flush toilet pull the flush lever upward and hold.

NOTE: R4 can be removed with wire cutters.

Part #	DESCRIPTION
1.	AM030+ Atlantes Seat & Cover (white)
2.	AM001+ Atlantes Bowl (white)
3.	M23 (17) #10 Lockwasher S/S
4.	F111 (4) 10-32 S/S Nut
5.	AM101*A Motor
6.	31-102 Motor Shaft Seal
7.	AM110 Discharge Pump Back
8.	F122VT(2) 10-32 x 3/8" Set Screw S/S
9.	AM120W Discharge Impeller Assy.
10.	AM031 Discharge Connection (3 pieces)
11.	AM114 Discharge Pump "O" Ring
12.	AM132 Macerator Teeth
13.	AM130 Discharge Pump Body
14.	F143VT(2) 10-32 x 1" Pan hd. SLTD S/S Screw
15.	1226B(7) 1/4-20 Nut S/S
16.	1118(8) 1/4" Locking Star Washer
17.	CH121 Macerator
18.	AM141 Discharge Cover O-Ring
19.	AM020A Pump Assy. Mounting Bracket
20.	F145VT(1) 10-32 x 1 3/4" Pan hd. SLTD. S/S Screw
	F142VT(8) 10-32 x 5/8" Pan hd. S/S Screw(not shown)
21.	AM026(2) Grommet
22.	AM140 Clear Macerator Cover
23.	F148VT(8) 8-32 x 7/16" S/S Truss Head Screw
24.	C254 Joker Valve
25.	1222AW 90° Discharge w/Flange
26.	F147VT(2) 3/8-16 x 1 1/2" Rnd Head Screw S/S
27.	1222B Straight Discharge (Optional)
28.	F146VT(2) 1/4-20 x 1 1/4" Rnd Head Screw S/S W/VT
29.	1226A 1/4-20 x 1 1/4" Rnd Head Screw S/S
30.	AM510 Intake Pump Mounting Bracket
31.	AM220W Impeller Assy.
32.	AM205AW Intake pump Assy.
33.	CWPS*A 1/2" GC Solenoid Valve
34.	CWPSMB Mounting Bracket for CWPS*
41.	31-307W T-Check Valve Assembly Complete
42.	CH43 (5) Hose Clamp S/S
43.	AM517 Inlet "J" Hose
44.	AM516 Inlet "L" Hose
45.	1236E Bowl Elbow
	41-260 Bowl Elbow (Fresh Water Units)
46.	AM011 Elbow: 3/4" 90 Degree FIPT x FIPT
47.	AM012 Nipple: 3/4" x 2" PVC SCH. 80
48.	1236AW Spud Assembly
49.	F084§ 8-32x1/2" Flat Hd. Hex Socket Screw S/S
50.	AM503§ Water Saver Lever
51.	AM502§ Flush Lever
52.	AM504§ Flush Control Nut
54.	AM060* Continuous Duty Solenoid
55.	AM505§ Flush Cam
56.	AM506§ Water Saver Cam
57.	F030VT(1) 1/4-20 x 2" Rnd Hd. Screw S/S
58.	F035(3) Isolation Nut
59.	AM521 Fuse/Solenoid Bracket
60.	AM507W Timer Mounting Plate and Splash Guard for A5
61.	RPR2 (2) 1/8 x 1/4" Pop Rivet
62.	C252 Fuse Block
64.	ATC** Flush Control Circuit Board
65.	F086VT 1/4-20x1 3/4" Rnd Hd. Screw S/S
66.	1124(2) 1/4-20 x 1/2" Rnd Hd. Screw S/S
67.	M31 (4) 1/4" Brass Flat Washer
68.	RNI Nylon Shoulder Washer
69.	F069 1/4" Fiber Washer
70.	F144 (2) #10 S/S Flat Washer
71.	HLWQB(2) 1/4" Split Lock Washer
72.	HSB1 1/4-20 Brass Screw

§Parts are NOT included with Wall Switch Flush Control Models

Part #	DESCRIPTION
73.	M30 (2) 1/4-20 Brass Nut
74.	F012 (2) #6 1/4" Pan Hd. S/S Screw
75.	AM028 (2) Bushing
76.	1239 (2) 1/4" Split Lock Washer
	AWH01 Wire Harness (not shown)
	CWPSMB Mounting Bracket for CWPS*(Fig. #5A)
	JHSD* 1" Intake Solenoid Valve, Marinized (not shown)
	F071 Nylon Shoulder Washer (not shown)
	AM203 Remote Inlet Pump Base (not shown)
	RTAH24D Transformer/Rectifier for 120/240 VAC (not shown)
89.	PLAVB0-5 Atmospheric Vacuum Breaker
90.	PLA5 1/2" MPT PVC Nipple
91.	PLA6 1/2" FPT to 3/4" Barbed Elbow
92.	PLA7 1/2" MPT to 3/4" Barbed Nipple

DEODORANT/SALT FEED PARTS LIST

77.	31-301 Salt Feed Tank
78.	31-302 Salt Feed Tank Cap
79.	31-304C Plastic Tubing Clamp
80.	31-304F Bulkhead Fitting
81.	31-304G Bulkhead Fitting Nut
82.	31-304H Bulkhead Fitting Seal
83.	31-304W Assembly (includes part #'s 31-304C, 31-304F, 31-304G, 31-304H, 31-305)
88.	31-305 Tubing 1/4"

T-CHECK VALVE PARTS LIST

35.	31-307D Valve Body
36.	31-307D1 Outlet Adapter
37.	31-307E "O" Ring
38.	31-308W Siphon check valve
39.	CH12 Check Ball
40.	CH8 Check Valve Spring
41.	31-307W T-Check Valve Assembly Complete

A6 WALL SWITCH FLUSH CONTROL

29.	1226A 1/4-20 x 1 1/4" Rnd Hd. Screw S/S
74.	F012 (2) #6 1/4" Pan Hd. S/S Screw
75.	AM028 Bushing
84.	AM507AW Timer Mounting Plate and Splash Guard for A6
85.	ATW603 Wall Switch Control Panel
86.	31-604 Control Indicator Panel Cable(14 ft.)
87.	ATW** Flush Control Circuit Board

FUSES/CIRCUIT BREAKERS

AM091	Circuit Breaker, 15A
AM090A	Circuit Breaker, 35A
AM092	Circuit Breaker, 4A
AM093	Circuit Breaker, 20A
AM094	Circuit Breaker, 10A
EF5FA	Fuse: Flush Control Circuit Board
34-218	Fuse, MDL5, 32V
34-220	Fuse, MDL20, 32V

Different units require different combinations of fuses. Use blown breaker/fuse to determine correct size replacement, contact Raritan Technical Support or refer to Specification Table #2.

ADDITIONAL ACCESSORIES AVAILABLE FROM RARITAN

163000	In-Line Strainer
1PCP22	C.P., Cleans Potties, Bio-enzymatic, 22 oz.
YV	"Y" Valve
SH	Sanitation Hose (sold by the foot)
CON22	Raritan Concentrate 22 oz. bottle
AHRK	Atlantes Toilet rebuild kit
AHDA1W	Internal Vented Loop
VL 3/4	Vented Loop 3/4"
VL 1 1/2	Vented Loop 1 1/2"

SERVICE AND REPLACEMENT PARTS

Replacement parts may be ordered through your local Raritan dealer or directly from the factory. When ordering please state part #, description and quantity required. With some parts you may need to know voltage. Questions or problems may be referred to Raritan's Technical Support Department.

+CHOICE OF COLOR

*SPECIFY VOLTAGE

EXPLODED PARTS VIEW FOR ATLANTES TOILETS

A6 WALL SWITCH FLUSH CONTROL

ATMOSPHERIC VACUUM BREAKER

SOLENOID VALVE

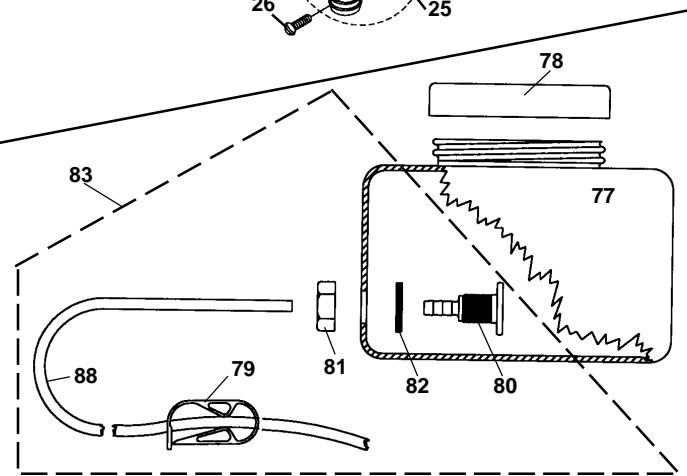
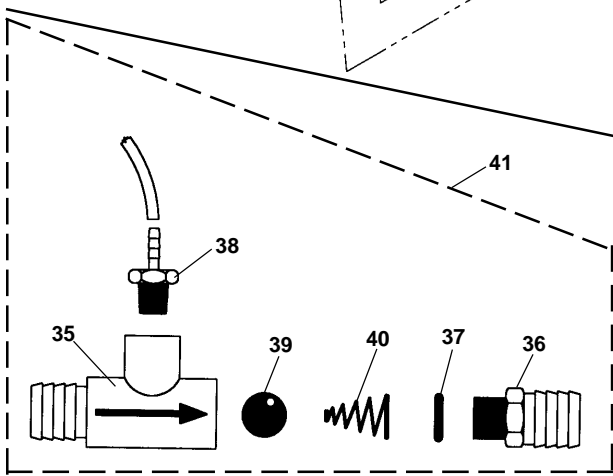
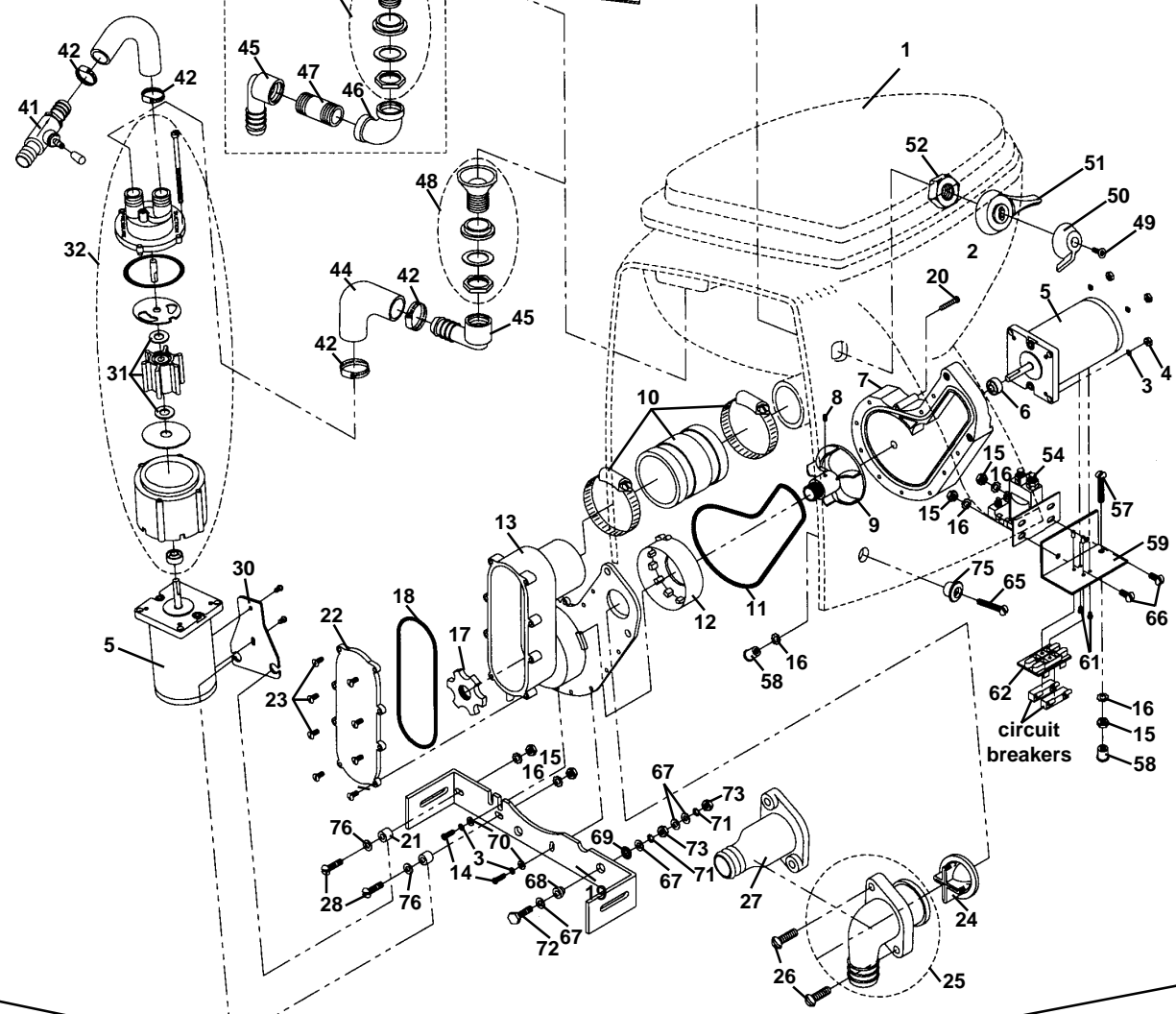
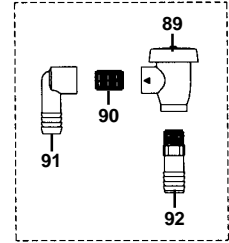
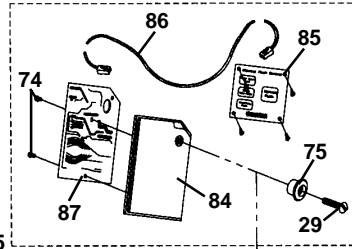
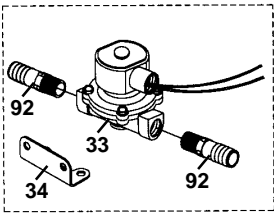

LIMITED WARRANTY

Raritan Engineering Company warrants to the original purchaser that this product is free of defects in materials or workmanship for a period of one year from the product's date of purchase. Should this product prove defective by reason of improper workmanship and/or materials within the warranty period, Raritan shall, at its sole option, repair or replace the product.

1. TO OBTAIN WARRANTY SERVICE, Consumer must deliver the product prepaid, together with a detailed description of the problem, to Raritan at 530 Orange St., Millville, N.J. 08332, or 3101 SW 2nd Ave. Ft. Lauderdale, FL 33315. When requesting warranty service, purchaser must present a sales slip or other document which establishes proof of purchase. **THE RETURN OF THE OWNER REGISTRATION CARD IS NOT A CONDITION PRECEDENT OF WARRANTY COVERAGE.** However, please complete and return the owner Registration Card so that Raritan can contact you should a question of safety arise which could affect you.
2. **THIS WARRANTY DOES NOT COVER** defects caused by modifications, alterations, repairs or service of this product by anyone other than Raritan; defects in materials or workmanship supplied by others in the process of installation of this product; defects caused by installation of this product other than in accordance with the manufacturer's recommended installation instructions or standard industry procedures; physical abuse to, or misuse of, this product. This warranty also does not cover damages to equipment caused by fire, flood, external water, excessive corrosion or Act of God.
3. **ANY EXPRESS WARRANTY NOT PROVIDED HEREIN, AND ANY REMEDY FOR BREACH OF CONTRACT WHICH BUT FOR THIS PROVISION MIGHT ARISE BY IMPLICATION OR OPERATION OF LAW, IS HEREBY EXCLUDED AND DISCLAIMED. ALL IMPLIED WARRANTIES SUCH AS THOSE OF MERCHANTABILITY AND OF FITNESS FOR A PARTICULAR PURPOSE, IF APPLICABLE, AS WELL AS ANY IMPLIED WARRANTIES WHICH MIGHT ARISE BY IMPLICATION OF LAW, ARE EXPRESSLY LIMITED TO A TERM OF ONE YEAR. SOME STATES DO NOT ALLOW LIMITATIONS ON HOW LONG A LIMITED WARRANTY LASTS, SO THE ABOVE LIMITATION MAY NOT APPLY TO YOU.**
4. **UNDER NO CIRCUMSTANCES SHALL RARITAN BE LIABLE TO PURCHASER OR ANY OTHER PERSONS FOR ANY SPECIAL OR CONSEQUENTIAL DAMAGES, WHETHER ARISING OUT OF BREACH OF WARRANTY, BREACH OF CONTRACT, OR OTHERWISE. SOME STATES DO NOT ALLOW THE EXCLUSION OR LIMITATION OF INCIDENTAL OR CONSEQUENTIAL DAMAGES, SO THE ABOVE LIMITATION OR EXCLUSION MAY NOT APPLY TO YOU**
5. No other person or entity is authorized to make any express warranty, promise or affirmation of fact or to assume any other liability on behalf of Raritan in connection with its products except as specifically set forth in this warranty.
6. This warranty gives you specific legal rights, and you may also have other rights which vary from state to state.



RARITAN
Engineering Company, Inc.

530 Orange Street, P.O. Box 1157, Millville, NJ 08332 USA
Telephone: 856-825-4900 FAX: 856-825-4409
www.raritaneng.com
3101 SW Second Avenue, Fort Lauderdale, FL 33315 USA
Telephone: 954-525-0378 FAX: 954-764-4370