

# TECHNICAL BULLETIN

## USE OF LECTRA/SAN MC ON INSPECTED VESSELS

We receive numerous inquiries as to what modifications of the Lectra/San MC (which is certified for uninspected vessels) are necessary for Coast Guard acceptance on inspected vessels (65 feet in length or less).

Connection of an electric marine toilet to a Lectra/San MC (using the toilet control circuit) makes operation of the system very simple for all types of boats.

We recommend the use of manual toilets equipped with manual sensors for Lectra/San MC installations on "head" boats because of the difficulty in properly instructing large groups of passengers as to the correct use of the system without the sensor.

On "charter" boats that go beyond the three mile limit (nine miles in the Gulf of Mexico) carrying eight or more passengers or crew, we recommend that a "Y" valve be installed between the head and the treatment unit to reduce the duty cycle by discharging waste sewage beyond the three mile limit without treatment (which is legal).

Installation of the Lectra/San MC is approved for a inspected vessel if plumbing and electrical installation of the vessel is in compliance with 46CFR subchapter F and subchapter J. Copies of these regulations pertaining to inspected vessels (46CFR) can be obtained from the internet at the address:

<http://www.access.gpo.gov//nara/cfr/index.html>

Applicable requirements for an MSD from Title 46 CFR are section 50 to 63 and section 110 to 113.

### INSTALLATION OF THE LECTRA/SAN MC ON AN INSPECTED VESSEL

In addition to the installation requirements in the Installation and Maintenance Instructions (L270), some of the following requirements are specific to the MSD installation in 46 CFR subchapter F and S. There may be additional requirements, not listed below, which must be met before a vessel is inspected and approved.

#### PLUMBING

1. Piping, tubing, pipe joining fittings and pipe system components shall meet material and standard requirements of 46 CFR subpart 56.60 and shall meet certification requirement of part 50 of the subchapter as per 46 CFR 56.10-1.

**NOTE: As per 46 CFR 56-60-25 (3) nonmetallic flexible hose may be used for plastic pipe in non vital fresh and salt water systems and non-vital pneumatic system subject to the limitation of paragraph (a) (1) through (6) of section 56-60. Unreinforced hoses are limited to a maximum service pressure of 50 PSI, reinforced hoses are limited to a maximum service pressure of 150 PSI.**

2. Periodically inspect for leaks and check for loose plumbing and electric connections as per 46 CFR 61.01-1 and maintenance section of Installation and Maintenance Instruction (L270).
3. Follow Recommission and Start up instructions in Installation and Maintenance Instructions (L270) to periodically test piping system as per 46 CFR 61.15-1.

## ELECTRICAL

1. In addition to meeting wire size and fuse/breaker ratings as per specification table in L270, all electrical wiring, overcurrent protection and grounding should comply with section 110 to 113 of 46 CFR subchapter J.
2. **Grounding:** Exposed electrical motors on Lectra/San should be grounded to comply with 46 CFR 111.05-3. Unscrew the nut on top of the mixer and macerator motor as shown in Figure #1. Place the ground wire on mixer and macerator motor and tighten the nuts. Remove the nut and washer from left hand side of mounting plate (to the left of fuses) and place grounding wire as shown in Figure #2. Replace the washer and nut. Ground the mounting plate to the boat's grounding system.
3. Plans of electrical wiring and schematic specific to the vessel as per 46 CFR 110.25-1 should be submitted to Coast Guard review in accordance with 46 CFR sec. 110.25-3.

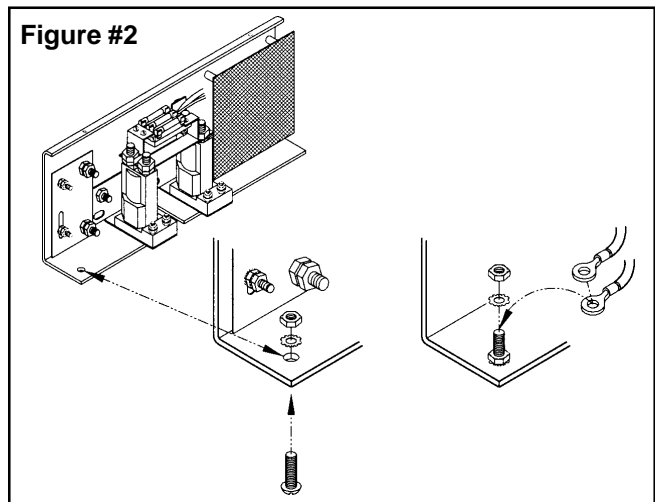
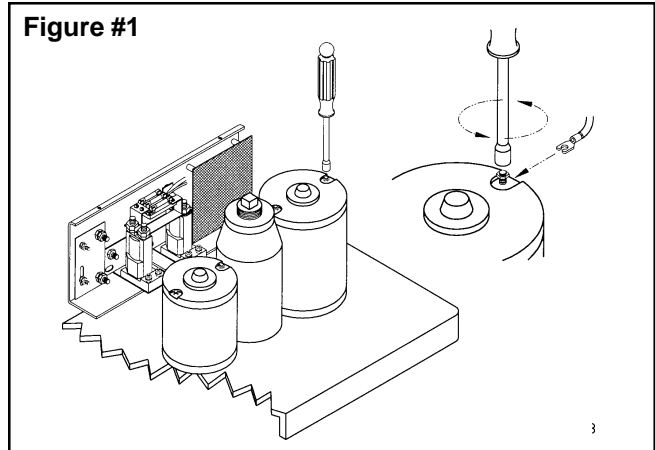

For more information on Inspected vessels requirements please contact your local coast guard inspector or:

Commandant G-MSE-3  
United States Coast Guard  
System Engineering Division  
2100 Second Street, S.W.  
Washington, DC 20593-001



**RARITAN**  
Engineering Company, Inc.

530 Orange Street, P.O. Box 1157, Millville, NJ 08332 USA  
Telephone: 856-825-4900 FAX: 856-825-4409  
www.raritaneng.com  
Southern Office and Plant:  
3101 SW Second Avenue, Fort Lauderdale, FL 33315 USA  
Telephone: 954-525-0378 FAX: 954-764-4370