



CROWN II "F" SERIES CURRENT-LIMITING MARINE CONVERTERS

INSTALLATION and MAINTENANCE INSTRUCTIONS

THE FOLLOWING ARE CAUTIONARY STATEMENTS THAT MUST BE READ AND FOLLOWED DURING BOTH INSTALLATION AND OPERATION

WARNING:  *Raritan Engineering Company Inc. recommends that a qualified person or electrician install this product. Equipment damage, injury to personnel or death could result from improper installation. Raritan Engineering Company Inc. accepts no responsibility or liability for damage to equipment, injury to personnel or death that may result from improper installation or operation of this product.*

WARNING:   **Hazard of Shock or Fire** - Use only recommended fuse/circuit breaker and wire size.

IMPORTANT SAFETY INSTRUCTIONS

WARNING: Safety instructions must be followed. Failure to do so may result in damage to equipment, injury to personnel or death.

CAUTION: To reduce the possibility of injury, charge ONLY lead/acid type rechargeable batteries.

1. Before using or installing the converter, read all instructions and external cautionary markings on (1) the converter, and (2) the batteries.
2. Do not expose the converter to rain, snow or spray.
3. Any modification to the converter or the use of attachments not recommended by Raritan Engineering Co. Inc., may result in a risk of fire, electric shock, or injury. Any auxiliary switches in the boat's low voltage system should be U/L recognized and rated for DC use.
4. Do not use an extension cord with the converter.
5. Do not operate the converter if it received a sharp blow, was dropped, submerged or exposed to spray; consult a qualified service person or return it to the factory for servicing. If returning to the factory, be sure to include return address, phone number where you can be contacted during business hours, and a brief description of the damage or problem associated with the unit.
6. Only a qualified electrician or service person should troubleshoot or repair the converter.
7. To reduce the risk of an electric shock, disconnect the converter from the power supply before attempting any maintenance or cleaning. Turning the switch to the "off" position does not disconnect the converter from the power supply.
8. Do not connect the converter to a frozen battery.
9. Do not smoke, strike a match, or cause a spark in the vicinity of a battery.

10. The water in each cell should be at the correct level before charging.

11. Wear eye protection whenever working in the vicinity of batteries.

INTRODUCTION

Raritan Converters are fully automatic solid state units designed to convert shore line current (120volt 60 HZ) to DC current for onboard battery maintenance, lighting and general marine use. Input voltage and amperage requirements are specified on the data label on the face of each model, along with DC output voltage and amperage rating.

The converter uses a low-weight Ferroresonant transformer. The current limiting value and the output voltage is preset in the transformer at the factory to cover a wide range of input voltages.

The transformer output is divided into three separate full wave center tap (FWCT) circuits to maintain three separate batteries, or three banks of batteries. Heavy duty rectifiers, mounted on efficient heat sinks for long life, are used throughout.

A DC ammeter monitors output during charging. An automatic reset circuit breaker is provided for protection against abnormal conditions such as high amperage or high temperature operation.

NORMAL OPERATION

Under normal operation the indicator light will be on and the DC ammeter will show a charge current to the batteries. A light hum from the transformer is normal. Initially the ammeter will start at a higher reading and slowly drop to less than an ampere as the batteries are charged. On/off switch is provided to turn off the unit. Optional remote control indicates power and charge status remotely.

INSTALLING A RARITAN CONVERTER

Materials Required: Wires per Tables 1 and 2, terminals, crimping tools, battery connectors, 1/4 - 20 mounting bolts, nuts and washers.

MOUNTING

Where To Mount The Converter

1. Select a dry area as close to the batteries as possible but preferably outside a high temperature area such as the engine compartment. The converter should be within 15 feet of the batteries to be charged. Do not install where battery acid fumes will be present or where water will drip on the unit.
2. Mount the converter on a vertical plane.
3. The converter needs to dissipate heat when in operation; allow at least 3" of air space at the top and the bottom for air circulation.
4. Leave at least 6" at the side for wiring convenience.
5. If a small compartment must be used, make sure ventilation is adequate via louvers, etc. and keep this area clear of obstructions.

How to Mount the Converter

1. Mount converter vertically with the data label right side up and case perforations at top and bottom.
2. Secure with corrosion resistant machine bolts, flat washers, lock washers and nuts. At least four bolts should be used. When nuts are tightened, 1/4" or more of the bolt should protrude through each nut.

WIRING

WARNING: Read all safety precautions before wiring converter.

CAUTION: Raritan Crown II Current-Limiting converters are designed for 120 volt 60 HZ power only. If application uses 50 HZ input, contact Raritan Customer Service for recommendations, as Raritan manufactures Crown converters for 50/60 HZ input in B-Series configuration.

1. Remove jumpers from positive output connections if wiring to more than one bank of batteries.
2. Connect converter DC leads and shore power line as shown on wiring diagram. Make the converter to battery (DC) connections first. The converter case must be grounded to AC shore ground. A pressure terminal is provided for this purpose.
3. Use strain relief connectors for wires or cables for

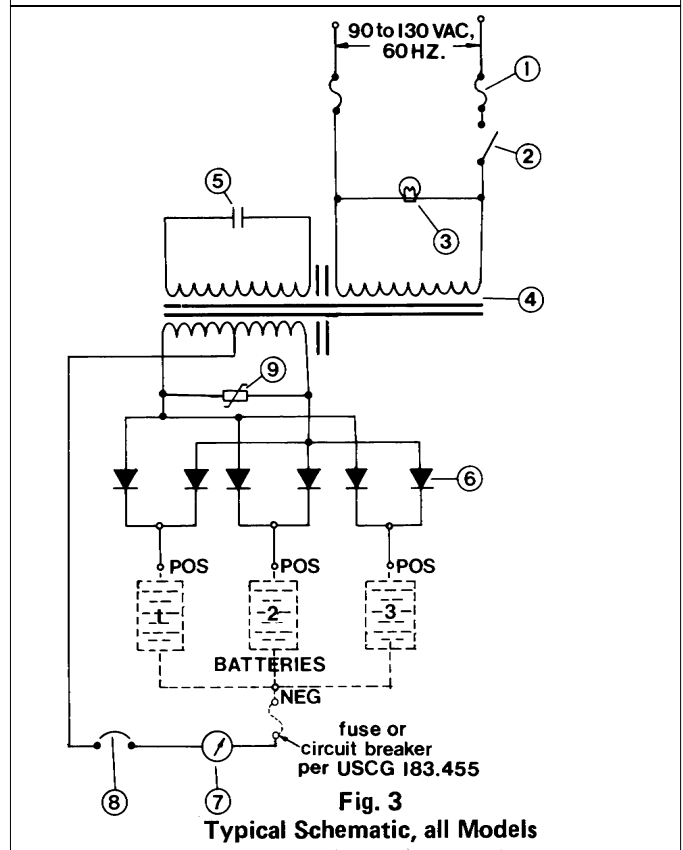
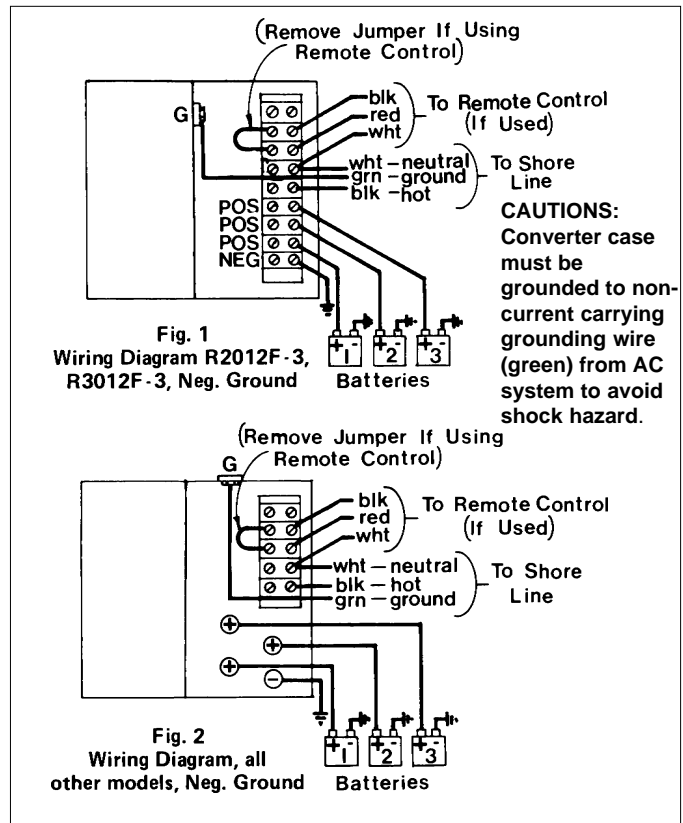

input and output wiring, and conduit connectors for conduit wiring.

WARNING: Hazard of shock. To avoid electric shock a Ground Fault Circuit Interrupter (GFCI) must be installed in AC supply circuit.

4. Use Tables 1 and 2 to determine AC and DC wire gauge sizes required, (derived from:) Standards And Recommended Practices For Small Craft, American Boat and Yacht Council, Inc., Box 806, Amityville, NY 11701, Sections "E8" and "E 9".

Table 1 Recommended Minimum Wire Sizes for 120VAC Shore Power Line NOT OVER 50 FEET LONG		
Model	AC Branch Circuit Breaker GFCI	AC Input Wire Size *
R2012F - 3	15 amp	No.14
R3012F - 3	15 amp	No.14
R4012F - 3	20 amp	No.12
R6012F - 3	20 amp	No.12
*Recommended conductor insulation 105°C (221°F) min.		

Table 2 Recommended Minimum Wire Sizes for DC Positive and Negative Cables, Distance Between Converter and Batteries NOT OVER 15 FEET		
Ampere Output	Wire Size	Fuse or Circuit Breaker For DC Wiring
20	No.10	30 Amp.
30	No. 8	40 Amp.
40	No. 6	50 Amp.
60	No. 4	70 Amp.

5. Do not run accessories directly off the converter leads. A battery MUST be connected in parallel with the converter.
6. A one time fuse or a manual reset circuit breaker must be used between the battery negative post and converter, in accordance with USCG # 183.455, for protecting wires - See Table 2 and Fig. 3.
7. Connect the AC input to a 120V AC power source using wire and GFCI recommended in Table 1.
8. **Grounding:** Connect non-current carrying grounding wire (green) from AC system to green terminal marked "G" and to pressure terminal on case.

START UP

Turn the converter "on". The red indicator light on the face of the unit will light and the converter will start charging the batteries if they require charging. The light on the converter will go out if the AC fuses are blown or if AC current is not reaching the converter.

CAUTION: To avoid fire and shock hazard NEVER use fuses higher than the amperage marked on the label adjacent to the fuse holder.

MAINTENANCE AND TROUBLESHOOTING

WARNING: Hazard of Shock - Working on any converter can be dangerous due to the high voltage AC and high amperage-low voltage DC involved. Troubleshooting and repair should be undertaken only by those who are technically competent, understand the dangers, and observe safety precautions. This converter is ignition protected. Replacing any part, not ordered through Raritan, may make this converter not ignition protected and may cause explosion if installed in an area requiring ignition protection.

Raritan Converters are fully automatic and designed to maintain a specific number of battery cells at 2.3 volts/cell. Number of cells and nominal voltage of the converter are listed on the converter cover face. Properly installed, Raritan converters are easily maintained. Simple troubleshooting can be accomplished by following the instruction in this manual. Before beginning any troubleshooting, do the following:

- Check to see if the shoreline power is on.
- Check all converter fuses and boat circuit breaker.
- Verify that all wires are properly connected; check that input and output wiring follows the schematic provided, and that DC polarity is correct.

How To Replace Diodes - Disconnect AC shoreline before working on converter. Remove cover after disconnecting the wires to the DC ammeter and the wires from the case at the terminal strip.

Models R2012F-3 and R3012F-3: Disconnect the transformer secondary leads from the heat sink assembly. Unscrew the #10 screw at each end of the bakelite mounting board from the side brackets. The entire rectifier assembly can now be removed and any diode within the assembly can be replaced.

All other models: Unsolder transformer secondary leads from secondary terminals. Unscrew the two bolts from diode assembly base. Remove the three #10 bolts from the finned heat sinks. You can now slide the entire rectifier assembly out from the base and any diode within the assembly can be replaced.

How To Replace The Transformer - It is recommended that the entire rectifier assembly (diodes with heat sinks) be removed to gain access to the transformer and its connections. The transformer may then be removed and replaced.

Any replacement parts required are available by calling Raritan Customer Service. Give converter model number, serial number, and part required.

TROUBLESHOOTING		
PROBLEM	POSSIBLE CAUSE	CORRECTION
A. 120 volt input fuses blown.	A1. Short in AC wires or transformer winding A2. Shorted AC capacitor. A3. Shorted varistor.	A1. Locate and repair short. A2. Replace capacitor. A3. Replace varistor.
B. Working properly but high hum.	B1. Transformer laminations are loose in center leg.	B1. Return to Raritan for repair.
C. No output with indicator light on and hum.	C1. Open DC circuit. C2. Defective internal circuit breaker. C3. Open diode(s).	C1. Check continuity of all wires back to batteries. C2. Replace internal circuit breaker(#8). C3. Replace diode(s).
D. Converter's internal circuit breaker tripping with no AC power.	D1. Shorted diode(s) drawing from battery.	D1. Replace diode(s).
E. Battery overcharging or undercharging.	E1. Old or deteriorated batteries.	E1. Check voltage and specific gravity of batteries. When fully charged & disconnected from converter, voltages should be no less than 13.2V for 12V, 26.4V for 24V and 36V for 32V systems.

PARTS LIST

No.	Part Name	R2012F-3	R3012F-3	R4012F-3	R6012F-3
1	AC Fuse (2)	RF7	RF7	RF7	RF10
2	On/Off switch	ROOS.....
3	Pilot Light	RIL.....
4	Transformer	RT2012F	RT3012F	RT4012F	RT6012F
5	AC Capacitor	RFC1	RFC2	RFC3	RFC4
6.	Diode (6)	RFD1	RFD1	RRD1	RFD60
7	DC Ammeter	R30AM	R40AM	R50AM	R60AM
8	Circuit Brkr	RFCB30B	RFCB40B	RKCB50	RKCB80
9	Varistor	MOV82V12	MOV82V12	MOV82V12	MOV82V12

SPECIFICATIONS

	Nominal DC Volt	DC Amps	Finishing Volts	AC Amps	AC Fuse	# of Lead Acid Cells
R2012F	12	20	13.8	4	MDL7	6
R3012F	12	30	13.8	5	MDL7	6
R4012F	12	40	13.8	7	MDL7	6
R6012F	12	60	13.8	10	ABC10	6
AC Input volts for all models 90-130V at 60 HZ.						
For specifications on 24 and 32V units contact the factory.						

LIMITED WARRANTY

Raritan Engineering Company warrants to the original purchaser that this product is free of defects in materials or workmanship for a period of one year from the product's date of purchase. Should this product prove defective by reason of improper workmanship and/or materials within the warranty period, Raritan shall, at its sole option, repair or replace the product.

1. TO OBTAIN WARRANTY SERVICE, Consumer must deliver the product prepaid, together with a detailed description of the problem, to Raritan at 530 Orange St., Millville, N.J. 08332, or 3101 SW 2nd Ave. Ft. Lauderdale, FL 33315. When requesting warranty service, purchaser must present a sales slip or other document which establishes proof of purchase. THE RETURN OF THE OWNER REGISTRATION CARD IS NOT A CONDITION PRECEDENT OF WARRANTY COVERAGE. However, please complete and return the owner Registration Card so that Raritan can contact you should a question of safety arise which could affect you.
2. THIS WARRANTY DOES NOT COVER defects caused by modifications, alterations, repairs or service of this product by anyone other than Raritan; defects in materials or workmanship supplied by others in the process of installation of this product; defects caused by installation of this product other than in accordance with the manufacturer's recommended installation instructions or standard industry procedures; physical abuse to, or misuse of, this product. This warranty also does not cover damages to equipment caused by fire, flood, external water, excessive corrosion or Act of God.
3. ANY EXPRESS WARRANTY NOT PROVIDED HEREIN, AND ANY REMEDY FOR BREACH OF CONTRACT WHICH BUT FOR THIS PROVISION MIGHT ARISE BY IMPLICATION OR OPERATION OF LAW, IS HEREBY EXCLUDED AND DISCLAIMED. ALL IMPLIED WARRANTIES SUCH AS THOSE OF MERCHANTABILITY AND OF FITNESS FOR A PARTICULAR PURPOSE, IF APPLICABLE, AS WELL AS ANY IMPLIED WARRANTIES WHICH MIGHT ARISE BY IMPLICATION OF LAW, ARE EXPRESSLY LIMITED TO A TERM OF ONE YEAR. SOME STATES DO NOT ALLOW LIMITATIONS ON HOW LONG A LIMITED WARRANTY LASTS, SO THE ABOVE LIMITATION MAY NOT APPLY TO YOU.
4. UNDER NO CIRCUMSTANCES SHALL RARITAN BE LIABLE TO PURCHASER OR ANY OTHER PERSONS FOR ANY SPECIAL OR CONSEQUENTIAL DAMAGES, WHETHER ARISING OUT OF BREACH OF WARRANTY, BREACH OF CONTRACT, OR OTHERWISE. SOME STATES DO NOT ALLOW THE EXCLUSION OR LIMITATION OF INCIDENTAL OR CONSEQUENTIAL DAMAGES, SO THE ABOVE LIMITATION OR EXCLUSION MAY NOT APPLY TO YOU.
5. No other person or entity is authorized to make any express warranty, promise or affirmation of fact or to assume any other liability on behalf of Raritan in connection with its products except as specifically set forth in this warranty.
6. This warranty gives you specific legal rights, and you may also have other rights which vary from state to state.



RARITAN
Engineering Company, Inc.

530 Orange Street, P.O. Box 1157, Millville, NJ 08332 USA
Telephone: (609) 825-4900 FAX: (609) 825-4409
Southern Office and Plant:
3101 SW Second Ave., Fort Lauderdale, FL 33315 USA
Telephone: (954) 525-0378 FAX: (954) 764-4370