



PHII AND PHEII MARINE TOILETS

INSTALLATION AND MAINTENANCE INSTRUCTIONS

THE FOLLOWING ARE CAUTIONARY STATEMENTS THAT MUST BE READ AND FOLLOWED DURING BOTH INSTALLATION AND OPERATION

WARNING:  *Raritan Engineering Company, Inc. recommends that a qualified person or electrician in the case of PHEII, install this product. Equipment damage, injury to personnel or death could result from improper installation. Raritan Engineering Company, Inc. accepts no responsibility or liability for damage to equipment, or injury or death to personnel, that may result from improper installation or operation of this product.*

WARNING:  **Hazard of Flooding** - Any installation made below the waterline must have vented loops positioned properly and all hose connections should be double-clamped. Both intake and discharge seacocks should always be in the closed position when the toilet is not in use. Failure to do so may result in flooding, property damage and loss of life.

WARNING:  **Hazard of Fire** - Do not wire 120V PHEII motors without using specified rectifier. Do not operate PHEII series toilets with handle in place, serious bodily injury may occur.

INTRODUCTION

The PHII is a manual marine toilet. The PHEII has either electric push button or manual operation. Both toilets have the same overall dimensions. An electric drive (#PHECKII) that mounts between the bowl and pump converts a PHII to a PHEII with no additional floor space required.

The PHII and PHEII are available with a Household-style bowl and seat or with the Marine-size bowl and seat.

Space requirements for each are as follows:

Models	Height	Depth	Width
Household-style bowl	14 1/2"	22 1/4"	18 1/4"
Marine-size bowl	14 1/4"	19 1/2"	17 3/4"

All models are suitable for use in conjunction with Raritan's Lectra/San MC®, a Coast Guard Certified Type I flow-thru Marine Sanitation Device (MSD) and/or holding tanks.

OPERATION

WARNING: DO NOT adjust valve handle (1209BW) while toilet is operating; bodily injury may occur.

The intake valve handle (#1209BW) must be in the open or "FLUSH" (counterclockwise) position to draw water in. When the valve handle is in the "DRY" position a special air valve allows the toilet to be pumped dry without pressure build up. In the "DRY" position, toilet will only pump out; no water will be brought into the bowl.

It is advisable to flush the toilet briefly before use to minimize staining. Pumping several strokes after the bowl has been flushed will help to clear the lines, minimize odor and reduce the possibility of backflow into the bowl. It may be necessary to change the valve handle from "FLUSH" to "DRY" more than once to properly evacuate the bowl.

Valve handle must be *fully* in the "FLUSH" or "DRY" position only.

Hard objects or stringy substances (paper towels, feminine hygiene products, filter cigarettes, etc.) *must not* be thrown into the toilet as they will cause damage.

RETURNING PHEII TO MANUAL OPERATION

WARNING: Secure circuit breaker in "OFF" position before proceeding.

In the event of a power loss or problem with the electrical system:

1. Remove arm bolt and nut (#1115 and #1115A) from the connecting rod (#1116BW).
2. Displace connecting rod (#1116BW) from track and push toward the back.
3. Insert the handle (#1206W) and cotter pin (#1210A). Be sure the handle is completely in the handle socket and secured by the cotter pin to avoid the possibility of breaking the plastic socket (#1210).

To return to electrical operation, reverse procedure.

MAINTENANCE

Using C.P. (#1PCP22) a bio-enzymatic toilet bowl cleaner (available from Raritan Engineering), will keep the bowl clean and fresh smelling. Introducing Raritan Concentrate into flush water through a Toilet Water Kit (#TWK) will deodorize and lubricate the unit.

Super Lube® (#SL) applied to the piston rod will prolong the life of the Piston Shaft Seal. This should be done every spring and fall or more regularly if the head is used frequently.

CAUTIONS: Using improper deodorants or cleaners can result in damage to rubber and plastic parts. DO NOT USE pine oil, formaldehyde, ammonia, ethyl acetate, phosphoric acid and concentrated chlorine bleach, petroleum or solvent based products.

PHEII units should have Super Lube® applied to the connecting rod (#1116B) slot where the roller oscillates and to the track on the side of the pump housing where the connecting rod travels up and down.

Before attempting repairs, refer to the Troubleshooting section of this manual.

STORAGE

Short Term Storage

If the toilet is not going to be used for up to one week, flush the toilet several strokes with the shutoff handle in the *wet bowl* position to clear all lines.

Long Term Storage

If the toilet is not going to be used for over a week, follow the short term storage, then switch to the *dry bowl* position and purge the toilet with at least two gallons of fresh water added to the bowl.

WINTERIZING

Improper winter lay up is a major cause of marine toilet failures.

1. Close the intake and discharge seacock. Disconnect and drain the intake and discharge hoses. Winterize seacocks and hoses.
2. You will need two buckets, three feet (1M) of 3/4" (19mm) hose, three feet (1M) of 1 1/2" (38mm) hose and a quart (1 liter) of non-toxic antifreeze.
3. Prepare one half gallon (1.9 liters) of an antifreeze/water mixture in a bucket (refer to the antifreeze

instructions for antifreeze/water ratio). Place intake hose in this bucket. Place discharge hose into the empty bucket. Pump toilet until antifreeze has circulated and is being discharged.

4. Antifreeze should remain in the toilet until recommissioning. This will protect both intake and discharge sides of the pump. Pouring antifreeze into the bowl will only protect the discharge side of the pump, allowing the intake side to possibly freeze.

NOTE: Holding tanks, seacocks and treatment systems need to be independently winterized, stored and recommissioned (see manufacturer's instructions).

RECOMMISSIONING

1. Lubricate piston rod with Super Lube®.
2. Using the buckets, hoses and a gallon (3.8 liters) of clean water, flush the antifreeze out of the toilet. Dispose of antifreeze properly, in accordance with local and federal regulations.
3. Reconnect the hoses and open both seacocks.
4. Check all connections for leaks with several test flushes.

INSTALLATION OF REPLACEMENT PARTS

1. Refer to Fig. #2 when replacing part #1228CW.
2. If Valve Body (#1203BW) is removed it must be positioned as in Fig. #3 for proper operation.

Overhaul kits containing the parts normally required to repair each unit are available. In addition, individual parts for your toilet may be ordered through your dealer or direct from the factory.

INSTALLATION

To install PHII and PHEII marine toilets, several installation accessories are required:

1. A nominal 3/4" (19mm) thru-hull fitting and seacock (shutoff valve).
2. 3/4" (19mm) I.D. reinforced intake hose and stainless steel hose clamps.
3. 1 1/2" (38mm) I.D. reinforced sanitation discharge hose (Raritan #SH) and stainless steel hose clamps.
4. A nominal 1 1/2" (38mm) discharge thru-hull fitting with seacock may be required, depending on the specific installation.

5. PHEII units require wire, terminal ends, a momentary switch and a relay (#PBS and #CDS).
6. PHEII units that will be operated on 120 VAC shore or generator power require a full wave bridge rectifier in the circuit. Raritan #CH104 is a combination rectifier and activating switch.

MOUNTING

PHII and PHEII may be mounted above or below the waterline (Figs #1 and 1A). Vented loops (#VL3/4 and #VL1 1/2) are required for below waterline installations and hose connections must be double clamped. Mount unit securely on a flat solid deck using stainless steel bolts backed up with nuts and large washers or stainless steel lag screws long enough not to pull out. **Never mount PHEII where it may be subject to shower spray or other sources of external water.**

PLUMBING

WARNING: Below waterline installations require vented loops. Top of the loop must be above waterline at greatest angle of heel. Intake vented loops must be installed between pump and back of the bowl. Discharge vented loops must be installed between the discharge of toilet and seacock. See Fig. #1 and #1A.

1. Route discharge hose above discharge outlet with a vented loop. This will enable the toilet to discharge more efficiently and will help to prevent backflow.
2. An In-Line Strainer (#163000) is recommended. This will help minimize odors and help prevent clogging.
3. Intake and discharge thru-hull fittings should be located far enough apart and in such a manner as to prevent discharge water from being drawn through the intake. One means of accomplishing this is to place them on opposite sides of the hull. Intake thru-hull should be located so that during shallow water conditions sand and other debris are not drawn into thru-hull fitting.
4. The optional Raritan Toilet Water Kit (#TWK) permits use of Raritan Concentrate (#CON22) with the PHII and PHEII toilets. Raritan Concentrate deodorizes the bowl and lubricates internal parts.
5. Test flush and check for leaks.

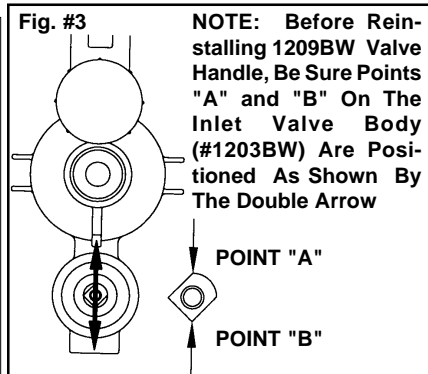
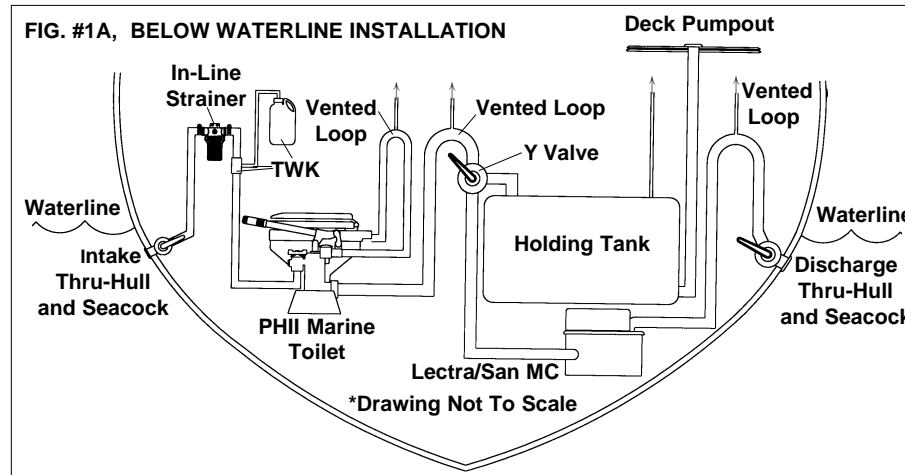
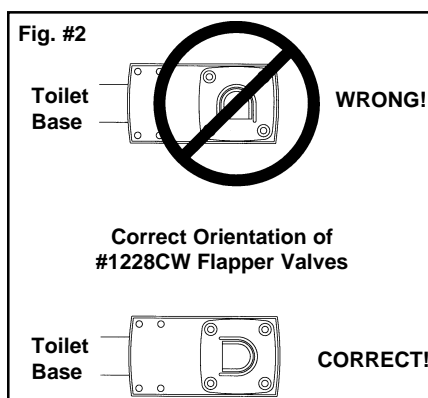
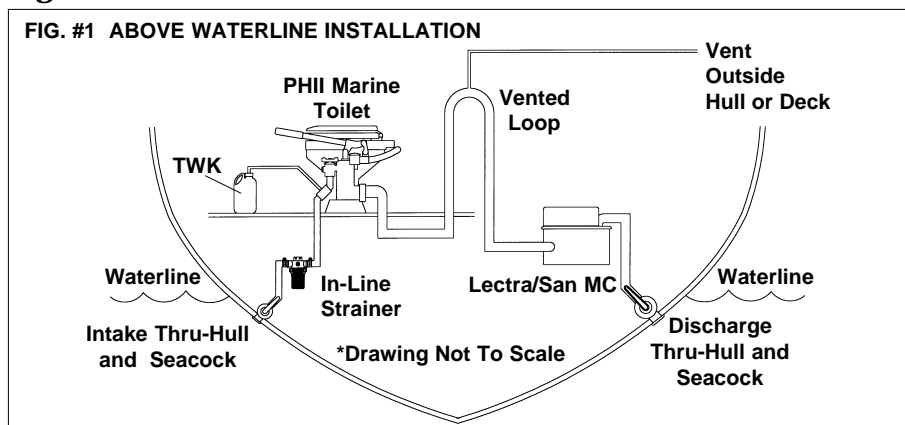

ELECTRIC CONVERSION KIT INSTALLATION (PHECKII) - For PHII Models Only

NOTE: It is recommended that the toilet be removed before installing the PHECKII.

1. Close the seacocks.
2. Remove cotter pin (#1210A) and handle (#1206W) from toilet. Disconnect hoses and unbolt toilet from deck.
3. Align connecting rod in track on side of pump housing and place motor-gearbox unit in position on base (#1248W) between pump and bowl.
4. Insert four hex head screws (#1119A) with lock washers (#1118). Tighten evenly.
5. Insert bolt (#1115) through connecting rod (#1116B) and thread into yoke (#1211PL). Tighten jam nut (#1115A) securely; this connection is not a pivot point.

WIRING THE PHEII

WARNING: DO NOT wire a 120V PHEII motor directly to 120VAC service unless a rectifier has been added to the circuit; motor burnout, short circuiting and fire could result.

Refer to Fig. #5 to determine correct wire and circuit breaker sizes. Locate fuses and circuit breakers for easy accessibility and on a circuit separate from other accessories. 12, 24 and 32 VDC units require a momentary switch and a heavy duty relay rated for continuous service. See Fig. #4 for wiring diagram. The momentary Push Button Switch (#PBS) and Continuous Duty Solenoid (#CDS) are available through Raritan.

All PHEII120 models and PHECKII120 conversion kits are supplied for DC operation. 120V DC units require a double-pole momentary switch rated for 10 amps inductive load (#CHDPS120). For AC operation, a full-wave bridge rectifier is required (#CH104) includes rectifier and one double pole switch).

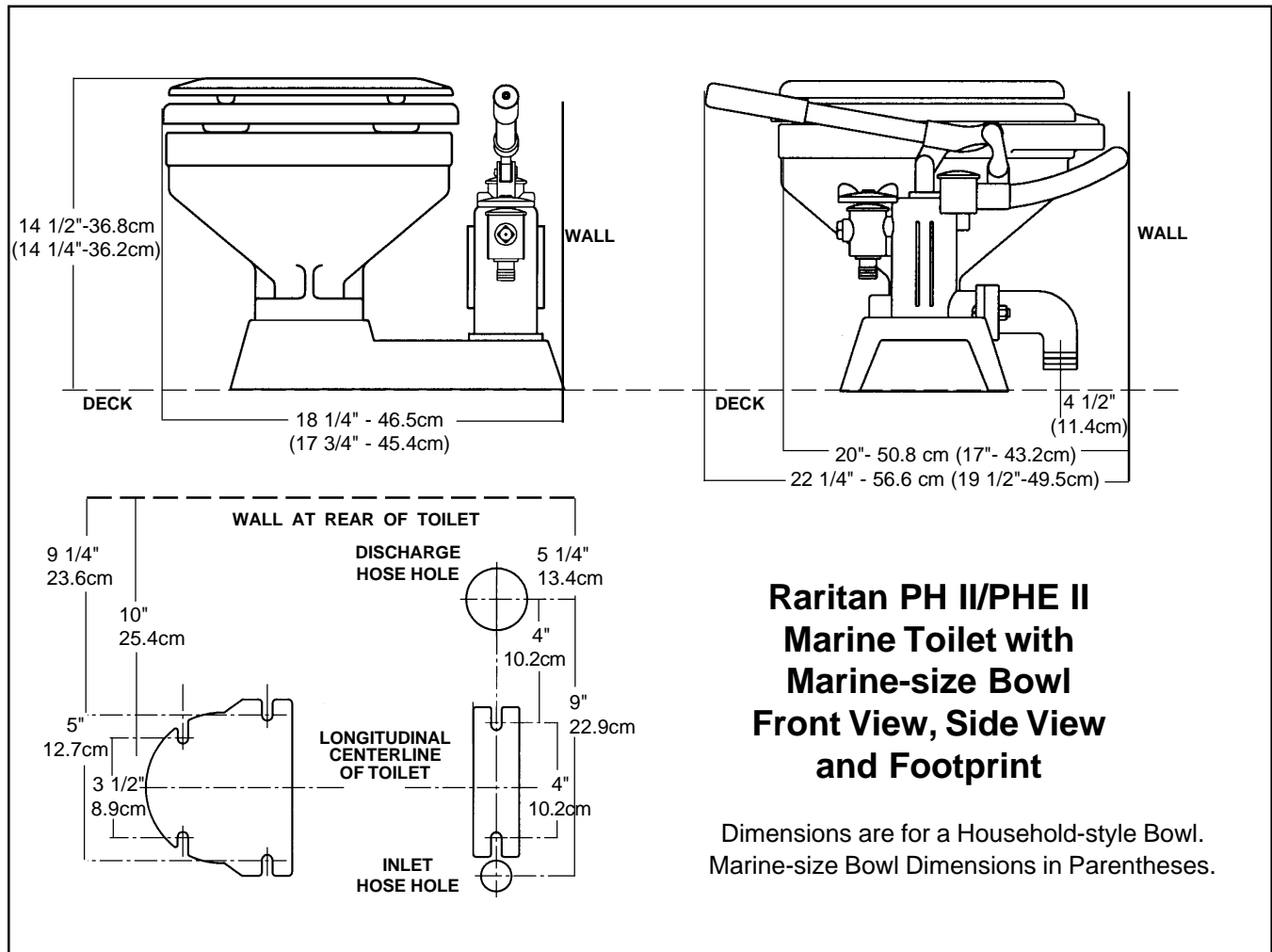

SPECIFICATIONS

Fig. #4 Wiring the PHEII (DC Unit with Momentary Pushbutton Switch)

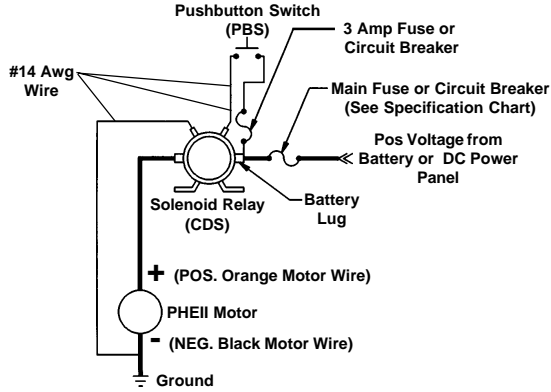

Electrical

Nominal Voltage (Volts DC)	12V	24V	32V
Amperage Draw @ Nominal Voltage	18	11	8
Circuit Breaker/Fuse Size (Amps)	25	20	12

For 120vdc units use 14 AWG (2.5mm²) wire.

Wire Sizes

NOTE: Recommended conductor sizes based on 105C rated insulation. Refer to ABYC Standards for other insulation ratings.

	Distance from source to unit and back to source [feet (m)]						
UNIT'S VOLTAGE	10'(3.1)	15'(4.6)	20'(6.1)	25'(7.2)	30'(9.2)	40'(12.2)	50'(15.2)
	Minimum recommended conductor wire AWG (mm ²) for 3% voltage drop						
12	10(6.0)	10(6.0)	8(10.0)	6(16.0)	6(16.0)	4(25.0)	
24	16(1.5)	14(2.5)	12(4.0)	12(4.0)	10(6.0)	10(6.0)	8(10.0)
32	16(1.5)	16(1.5)	16(1.5)	14(2.5)	14(2.5)	12(4.0)	12(4.0)

TROUBLESHOOTING

PROBLEM	POSSIBLE CAUSE	CORRECTION
A. Electric motor labors (pumps slowly) or handle is hard to pump on manual toilet.	A1. Low Voltage at motor while running A2. Air pocket in discharge line A3. Holding Tank vent clogged or tank full A4. Discharge line obstructed A5. MSD clogged A6. Discharge seacock closed.	A1. Check condition of batteries, terminals and wire connections for corrosion. Check gauge of wire to be sure it is not undersized. A2. Clean vent fittings. A3. Clean holding tank vent or empty tank as needed. A4. Check thru-hull fitting for clog. Remove discharge hose if necessary to free obstruction. A5. See MSD instruction manual. A6. Open discharge seacock.
B. Leak around piston shaft	B1. Cartridge seal worn. B2. Piston shaft scored.	B1. Replace piston shaft seal cartridge assembly. B2. Replace piston/rod assembly.
C. Water accumulates in the bowl too fast	C1. Flapper valve not seated properly C2. Joker Valve not closing or opening properly C3. Calcium build-up or blockage in hoses and fittings C4. Air pocket in discharge line	C1. Close intake valve and pump dry. Clean or replace flapper valve. C2. Close intake valve and pump dry. Clean or replace joker valve. NOTE: Routing discharge hose above toilet helps joker valve close tighter. C3. Clean affected parts or replace hose. C4. Bleed or clean vent fitting of vented loop or holding tank vent.
D. Water rises in bowl at dockside (toilet below waterline)	D1. Joker Valve leaking D2. Intake Valve leaking D3. Too much pressure against check ball	D1. Close discharge seacock, then intake seacock to determine which is causing the problem. Clean or replace joker valve. A vented loop is needed in the discharge. D2. Check for debris lodged under check ball. Replace O-rings, check ball, and spring if needed. D3. Vented loop must be installed between the bowl and pump (Fig. 1A).
E. Odor comes from head area when flushed	E1. Marine vegetation lodged in bowl E2. Intake water is foul E3. Back pressure from holding tank E4. Contaminated discharge hose	E1. Remove bowl and pressure flush from spud fitting at the back of the bowl. NOTE: Installing an In-Line Strainer (#163000) in the intake line will help prevent recurrence. E2. Raritan Toilet Water Kit (#TWK) and Raritan Concentrate (#CON22) will aid in deodorizing intake water. E3. Tank full or vent clogged. Discharge line blocked or kinked. Clean or replace as necessary. E4. Replace with Raritan Sanitation Hose (#SH).
F. Not enough water to rinse bowl	F1. Intake valve positioned improperly F2. Bowl rinse holes clogged F3. Intake line or strainer clogged F4. Debris around intake or discharge valve ball F5. Scored pump housing or worn piston "O" ring F6. Worn housing or seal cartridge is drawing air	F1. See Fig. 3. F2. Clean as needed. F3. Clean line or strainer. F4. Remove check balls and clean. F5. Replace housing or "O" ring as necessary. F6. Replace housing or cartridge.

Units requiring extensive repairs may be returned to the Millville, NJ or Fort Lauderdale, FL office for overhaul. Instructions, including name, address and phone number MUST accompany returned units to ensure proper handling.

**PARTS FOR RARITAN PHII AND PHEII
MARINE TOILET**

Part No.	Description
1115	3/8"-16 x 1 1/2" Hex Head S/S Bolt(2)
1124	1/4"- 20 x 1/2" R.H. Machine Screw
1200CW	Pump Housing
1201	Intake and Discharge Valve Ball (2)
1202	Intake and Discharge Valve Gasket (2)
1203BW	Intake Valve Body w/"O" Rings (1203B, 1203B1, 1203B2, 1203B3)
1203W	Air Valve Assembly
1204B	Intake Valve Cap
1206W	Handle
1209BW	Valve Handle
1210	Handle Socket
1210A	Cotter Pin (4)
1211PL	Piston Rod Yoke
1212W	Piston Rod Assembly w/"O" Ring (1232MS)
1213W	Piston Rod Seal Assembly, Pre-6/92, (Incl. 1213A, B, C, D)
1213A	"U" Cup Seal (Pre-6/92)
1213B	Delrin Washer (Pre-6/92)
1213C	Snap Ring (Pre-6/92)
1213D	White Neoprene Washer (Pre-6/92)
1214W	Piston Shaft Seal Cartridge Assy (1214, 1214A, 1214B) Fits pumps mfg. after 6/92
1216	Clevis Pin (3)
1217	Discharge Valve Cap
1218	Fulcrum Link (2)
1222AW	90° Discharge w/Flange (Std.)
1222B	Straight Discharge (Opt.)
1223B	Flange Nut 3/8"-16 S/S (2)
1226	Housing Screw 1/4"-20 x 1" S/S (4)
1226B	Nut, 1/4"-20 S/S (8)
1228CW	Flapper Valve Assembly (1/2" Holes)
1232MS	Piston "O" Ring
1234	Bowl Gasket
1236E	Bowl Elbow
1246W	Base Cover (2 pcs.)
1248W	Base w/Plug
1249	Base Plug
1250W	Base and Cover Assy.(1246W and1248W)
C253	Joker Valve
CH42	Hose (¾" I.D.)
CH43P	Hose Clamp (2)
F005	1/4"- 20 x 5/16" S/S Socket Set Screw
F081	Bowl Bolt 1/4"-20 x 2 S/S Hex head
LWS	Intake and Discharge Valve Spring (2)
RNI	Nylon Shoulder Washer

PARTS FOR ELECTRIC DRIVE

Part No.	Part Name
1100W	Gear Box Housing Assembly
1102	Worm
1104	Ball Bearing
1105	Snap Ring
1106AS	Rubber Connection w/Sleeve

Part No.	Description
1106W	Coupling w/Sleeve, complete
1108A	Motor Mounting Nut (2)
1109*	Motor (12, 24, 32, 120V DC)
1110	"O" Ring
1112	Link
1113	Link Pin, Worm Gear Pin
1115	3/8" - 16 x 1 1/2" Hex Head S/S Bolt
1115A	3/8" - 16 Hex Jam Nut S/S
1116BW	Connecting Rod Assy. (1116B, 1114B, 1114D)
1117B	Crank Bolt
1118	Lock Washer (4)
1119/1119A	Hex Head Screw (4)
1120W	Worm Gear Assy.(1111, 1113, 1120)
1122	"O" Ring
1123	Gear Box Cover
1124	1/4" - 20 x 1/2" R.H. Machine Screw(4)
M23A	#10 Lockwasher S/S (2)

PHC PARTS

Part No.	Description
1226A	Housing Screw 1/4"-20 x 1 1/4" S/S (4)
1226C	Plastic Spacer Washer (4)
1301PW	Toilet Base Assembly (1301P, 1343)
F081	Bowl Bolt 1/4" - 20 x 2" S/S Hex head

RARITAN INSTALLATION ACCESSORIES

Part No.	Description
163000	In-Line Strainer
164000	Push button switch
1PCP22	C.P., Cleans Potties, Bio-enzymatic, 22 oz.
CHTII	Compact holding tank - 5 gallon
CON22	Concentrate 22 oz. bottle
SH	Sanitation Hose (sold by the foot)
SL	Super Lube 1/2 oz. tube
TWK	Toilet Water Marine Head Disinfectant Kit
VL 3/4	Vented Loop 3/4"
VL 1 1/2	Vented Loop 1 1/2"
YV	"Y" Valve

BOWL & SEAT

Part No.	Description
1236AW	Spud assy.
1237W	Marine-size Bowl assy.
1244W	White Household-style Bowl assy.
1238A	Marine-size seat & cover
1245	Household-style seat & cover
1PCP22	Clean Potties, Bio-enzymatic, 22 oz.
VCAP	Vinyl Cap

OVERHAUL KITS

Part No.	Description
PHRKII	PHII&PHEII-U-cup Seal (mfg.before6/92)
PHRKIIC	PHII&PHEII-Cartridge Seal (mfg.after 6/92)
PHIIPUMP	PHII Pump replacement assembly

*Specify Voltage

EXPLODED PARTS VIEWS, PHII MARINE TOILET AND PHECKII ELECTRIC CONVERSION UNIT

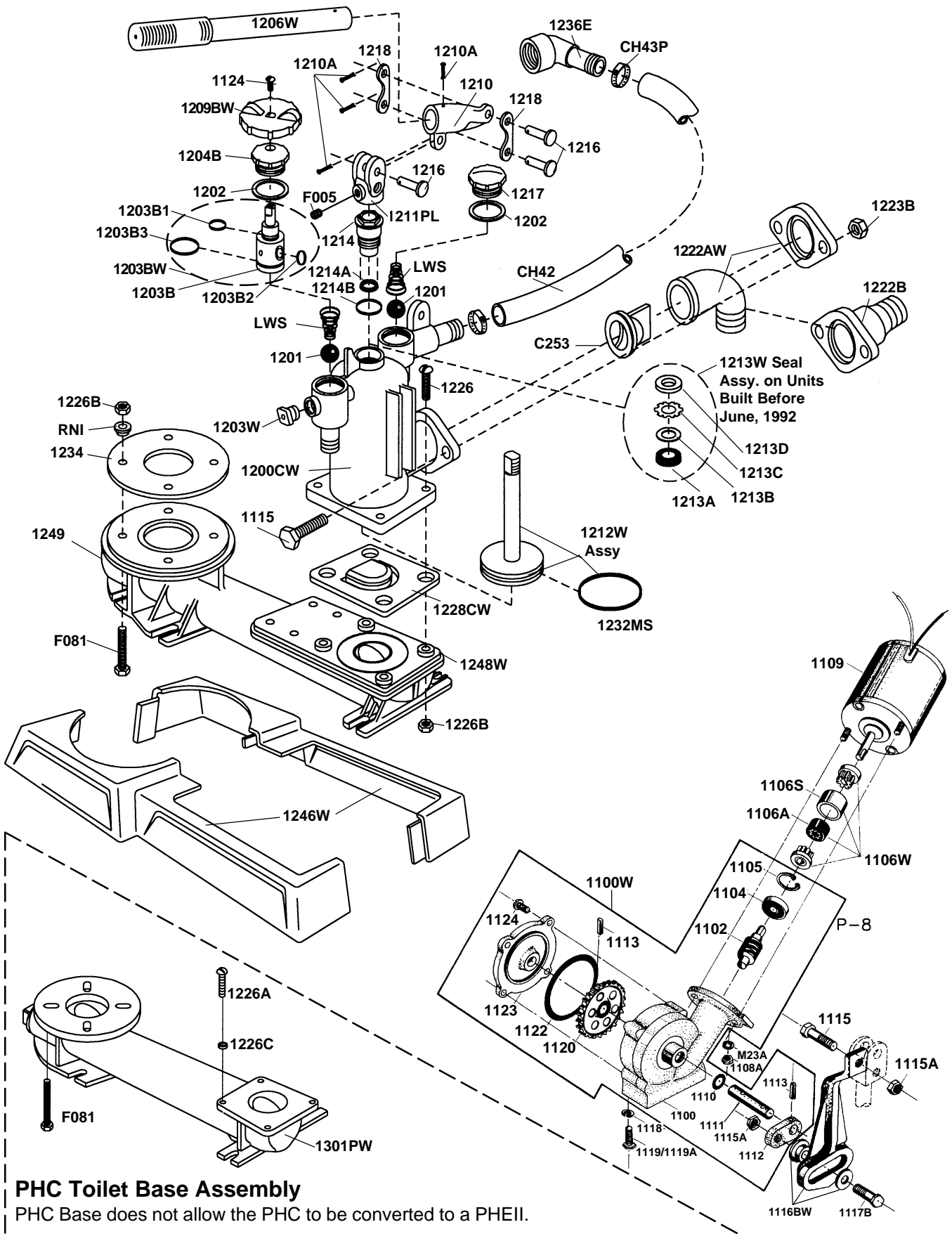

LIMITED WARRANTY

Raritan Engineering Company warrants to the original purchaser that this product is free of defects in materials or workmanship for a period of one year from the product's date of purchase. Should this product prove defective by reason of improper workmanship and/or materials within the warranty period, Raritan shall, at its sole option, repair or replace the product.

1. TO OBTAIN WARRANTY SERVICE, Consumer must deliver the product prepaid, together with a detailed description of the problem, to Raritan at 530 Orange St., Millville, N.J. 08332, or 3101 SW 2nd Ave. Ft. Lauderdale, FL 33315. When requesting warranty service, purchaser must present a sales slip or other document which establishes proof of purchase. THE RETURN OF THE OWNER REGISTRATION CARD IS NOT A CONDITION PRECEDENT OF WARRANTY COVERAGE. However, please complete and return the owner Registration Card so that Raritan can contact you should a question of safety arise which could affect you.
2. THIS WARRANTY DOES NOT COVER defects caused by modifications, alterations, repairs or service of this product by anyone other than Raritan; defects in materials or workmanship supplied by others in the process of installation of this product; defects caused by installation of this product other than in accordance with the manufacturer's recommended installation instructions or standard industry procedures; physical abuse to, or misuse of, this product. This warranty also does not cover damages to equipment caused by fire, flood, external water, excessive corrosion or Act of God.
3. ANY EXPRESS WARRANTY NOT PROVIDED HEREIN, AND ANY REMEDY FOR BREACH OF CONTRACT WHICH BUT FOR THIS PROVISION MIGHT ARISE BY IMPLICATION OR OPERATION OF LAW, IS HEREBY EXCLUDED AND DISCLAIMED. ALL IMPLIED WARRANTIES SUCH AS THOSE OF MERCHANTABILITY AND OF FITNESS FOR A PARTICULAR PURPOSE, IF APPLICABLE, AS WELL AS ANY IMPLIED WARRANTIES WHICH MIGHT ARISE BY IMPLICATION OF LAW, ARE EXPRESSLY LIMITED TO A TERM OF ONE YEAR. SOME STATES DO NOT ALLOW LIMITATIONS ON HOW LONG A LIMITED WARRANTY LASTS, SO THE ABOVE LIMITATION MAY NOT APPLY TO YOU.
4. UNDER NO CIRCUMSTANCES SHALL RARITAN BE LIABLE TO PURCHASER OR ANY OTHER PERSONS FOR ANY SPECIAL OR CONSEQUENTIAL DAMAGES, WHETHER ARISING OUT OF BREACH OF WARRANTY, BREACH OF CONTRACT, OR OTHERWISE. SOME STATES DO NOT ALLOW THE EXCLUSION OR LIMITATION OF INCIDENTAL OR CONSEQUENTIAL DAMAGES, SO THE ABOVE LIMITATION OR EXCLUSION MAY NOT APPLY TO YOU.
5. No other person or entity is authorized to make any express warranty, promise or affirmation of fact or to assume any other liability on behalf of Raritan in connection with its products except as specifically set forth in this warranty.
6. This warranty gives you specific legal rights, and you may also have other rights which vary from state to state.



RARITAN
Engineering Company, Inc.

530 Orange Street, P.O. Box 1157, Millville, NJ 08332 USA
Telephone: 856-825-4900 FAX: 856-825-4409
www.raritaneng.com
Southern Office and Plant:
3101 SW Second Avenue, Fort Lauderdale, FL 33315 USA
Telephone: 954-525-0378 FAX: 954-764-4370