

## PHC

Ideal for small sailboats and powerboats - **New** retractable handle enables owners to install toilet in confined areas more easily



All the benefits  
of the world-  
renowned PHII  
at a better price!

### **Benefits**

- Lever handle pumping – More efficient, simpler and cleaner than competing vertical piston pumps. No complicated hand or foot valves.
- Powerful flushing action - 66% Larger diameter housing and piston clears bowl quickly using less strokes than competition
- Pump construction - Engineered polymer offers superior strength and durability over PVC.
- Proven dependable design - incorporates precision check valves that ensure self priming capabilities up to 4 feet.
- Full size joker valve – reduces clogs and increases pump performance
- Conserves water – Simple ¼ turn valve allows boaters to easily utilize dry pump option
- Simple and flexible installation allows for mounting above or below waterline
- Each unit is assembled by hand, individually tested and built 100% in the USA.
- All units are backed by Raritan's one-year Limited Warranty and legendary technical support team.

*Raritan products are chosen by powerboat, sailboat, houseboat, and RV owners and manufacturers the world over for their dependability, environmental responsibility, simplicity of installation, operation, and maintenance. The product line includes house-hold style toilets, marine toilets, marine sanitation devices and systems, cleaning products, icemakers, water heaters, and rudder angle indicators.*

To view our complete line as well as obtain installation and servicing guides: visit [www.raritaneng.com](http://www.raritaneng.com)

# PHC

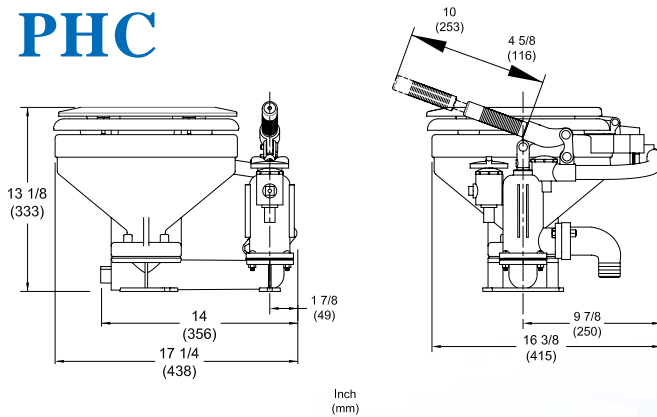

Approximate Shipping Weight: 26 lbs (12 kg)

Raritan kept the concept of space conservation that made the original model Compact ideal for fitting a real toilet into a small area and improved it by adding the most efficient dual action pump along with a newly added retractable handle. The retractable handle offers easy pumping while allowing it to be collapsed for maximum space in tight toilet areas.

A redesigned cartridge-type seal extends the life of the toilet and simplifies routine maintenance.

The PHC is designed for easy assembly and disassembly for maintenance. The standard 1½" discharge hose fitting is compatible with treatment devices or holding tanks. The PHC is an ideal replacement for portable toilets.

**Additional parts that are needed for installation:** Hose clamps, four stainless steel mounting bolts (minimum ¼" [6mm]) or lag screws and washers, 1½" (38mm) I.D. sanitation hose, and ¾" (19mm) I.D. reinforced hose.

## Model

Part#	Description
PHC	PHII Pump on a Compact II Base
PHIIPUMP	PHII Pump Assembly Complete

**Pump Advantages:** a double action piston pump simultaneously draws new flush water as it discharges the wastewater. By using raw water for flushing, on board water supplies can be reserved for essential freshwater use.

A simple quarter turn of the inlet water valve control knob allows the bowl to be pumped dry without using additional water. This provides the user with the option of emptying the bowl while in heavy seas. A special air vent reduces back pressure.



For more information contact:

Raritan Engineering Company Inc.  
530 Orange Street  
Millville, NJ 08332, USA  
Telephone: 856-825-4900  
Fax: 856-825-4409  
e-mail: info@raritaneng.com

Southern Plant and Office  
3101 SW 2nd Avenue  
Ft. Lauderdale, FL 33315, USA  
Telephone: 954-525-0378  
Fax: 954-764-4370

[raritaneng.com](http://raritaneng.com)