

MANAGERM

Type II MSD



Effective reliable treatment of onboard sewage for up to 12 persons per day. The Managerm is an aerobic biological sewage treatment system. The System uses air, water and the natural occurring bacteria to biologically convert waste to water and carbon dioxide (a harmless odorless gas)

- USCG Certified Type II Marine Sanitation Device also compliant with IMO Resolution MEPC2(VI)
- Tank constructed of lightweight corrosion resistant polyethylene
- Easy installation - Simple maintenance
- No foul odors
- No moving parts in contact with sewage
- Quiet, durable aeration pump included
- Low cost
- Uses very little electricity
- Operates with fresh, brackish and salt water
- No special tools are required for installation
- For use on inspected and uninspected vessels
- Works best with macerating toilets

Raritan manufactures equipment for pleasure boats throughout the world. Products include marine toilets, waste treatment systems, icemakers and water heaters.

Committed to the environment and preserving sea life, Raritan designs products to help maintain an environmental balance and ensure the quality of marine waters. In addition, the company has achieved ISO 9001:2000 certification for quality.

Innovation Through Experience

MANAGERM

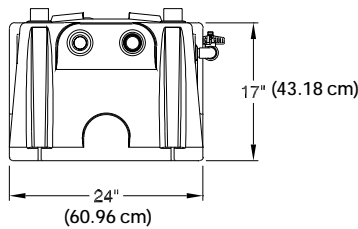
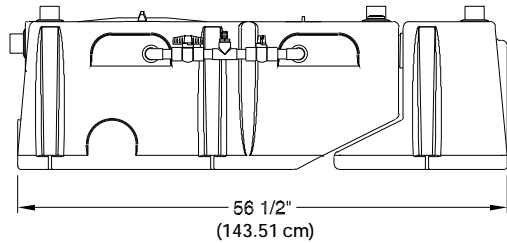

Specifications

MODEL # 6400121

Capacity -

12 persons/day

Weight -

Dry - 100 lbs. (45.36 Kg)

Wet - 575 lbs. (260.8 Kg)

Water -

Salt, Fresh or Brackish.

(Salt content must not exceed 4%)

Ambient Temperature Operating range -

Min. 40°F (4.5°C)

Max. 120°F (49°C)

Electrical -

Aeration pump - 120 VAC 1 amp. 50/60 HZ

Operation

The ManaGerM is a flow through system for black water only. It is an extended aeration bioreactor with a secondary disinfecting tank.

The ManaGerM has two tanks. The first tank has two chambers - the first chamber converts waste into water (H₂O) and carbon dioxide (CO₂) - the second chamber allows solids to settle and clarified water to pass on to the secondary tank,

Water displaced from the first tank moves through the tablet dispenser and into the secondary tank where disinfection takes place.

The ManaGerM works best with macerating and eductor (jet-type) toilets.

Sample Installation

The ManaGerM is intended for installations at or above the waterline of the boat. The outlet of tank is designed to drain, not pump upward.

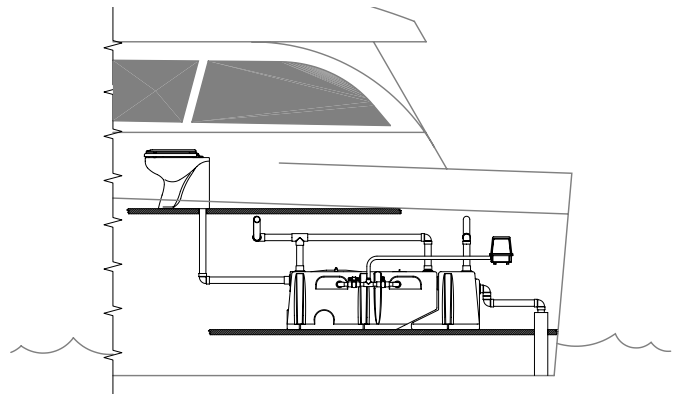

For more information contact:

Raritan Engineering Company Inc.

530 Orange Street, PO Box 1157

Millville, NJ 08332, USA

Telephone: 856-825-4900

FAX: 856-825-4409

e-mail: info@raritaneng.com

www.raritaneng.com

Southern Plant and Office

3101 SW 2nd Avenue

Ft. Lauderdale, FL 33315 USA

Telephone: 954-525-0378

FAX: 954-764-4370



Innovation Through Experience