

PURASAN EX EXPLODED VIEW

EXPLODED PARTS

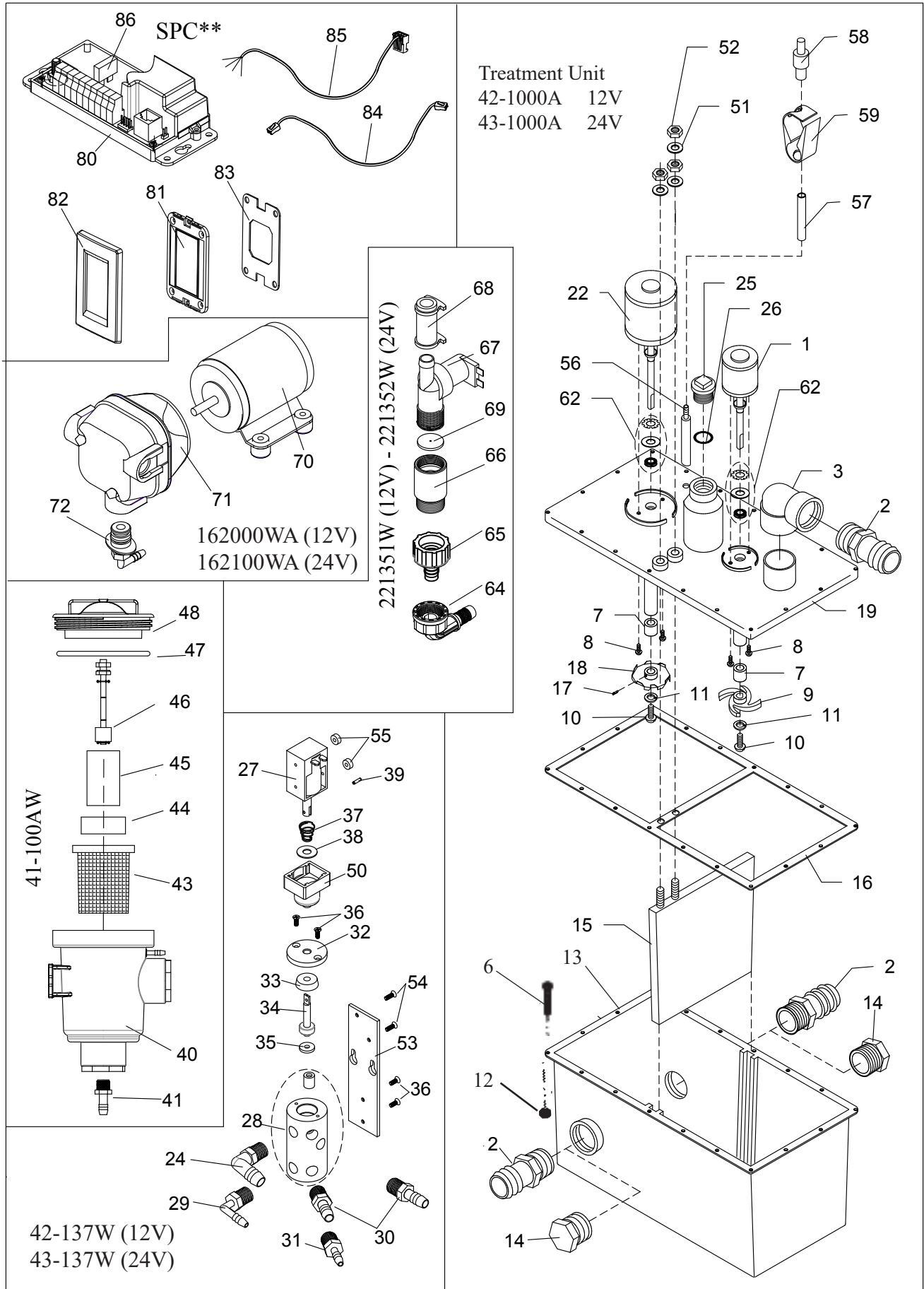

PURASAN EX PARTS LIST

Item	Part #	Description
1	32-102AW	Mixer Motor 2 1/2" Dia. 12 V DC
1	33-102AW	Mixer Motor 2 1/2" Dia. 24 VDC (1) includes shaft seals and bushing for mixer motor)
2	31-121	Hose Fitting (2) (Not shown) 90° hose fitting (PLA401)
3	31-120	Discharge Elbow 90°
6	31-134	Cover Hold down Bolt, 10-32 x 1" (18)
7	31-103	Motor Shaft Bushing (2) (see 62)
8	F351	Motor Hold down Bolt, 10-32x1", S/S (4)
9	31-109	Mixer Impeller
10	31-110-1	Impeller Bolt, 12-24 x 5/8", S/S (2)
11	31-110-2	Impeller Lock Washer, #12, S/S (2)
12	31-114	Cover Hold down Nut, 10-32 (18)
13	31-115PS	Treatment Tank
14	31-122	Intake Plug
15	41-102	Tank Divider
16	31-112	Cover Gasket
17	31-108	Macerator Set Screw
18	31-107	Macerator Impeller
19	41-101W	Treatment Cover (includes 56, 25,26)
22	33-101AW*	Macerator Motor for 12 and 24 VDC unit
25	31-104CW	Crossover Plug with O-ring (Includes 31-105)
26	31-105	O-Ring
51	M31	#14 Brass Flat Washer (4)
52	M30	1/4"-20 Brass Nut (4)
56	31-325A	Adapter Tank Lid
57	221335	Hose
58	41-170	Tank check valve
59	31-304C	Hose clamp

DRAIN MANIFOLD ASSEMBLY

42-137W (12V)

43-137W (24V)

24	41-151A	Adapter 1/4" x 1/2" elbow with check valve
27	42-145	12 Volt Pull Solenoid
	43-145	24 Volt Pull Solenoid
28	41-137	Drain Manifold assy.(with check valve)
29	41-151B	Adapter 1/4" x 1/4" elbow with check valve
30	41-141	Adapter 1/4" NPT x 1/2" barbed
31	PLA3	1/4" Barbed x 1/4" NPT Adapter
32	41-139	Cap, manifold
33	41-138C	1/4" x 3/4" U cup seal
34	41-138 B	Plunger
35	41-138A	Washer for plunger
36	F204	6-32 x 3/8" Flat head mach. screw(4)
37	LWS	Spring
38	F203	Washer 5/16" x 3/4"
39	F233	Spring Roll Pin
50	41-187	Shaft Boot
53	41-152	Base Plate
54	F232	6-32 x 7/16" Flat head mach. screw (2)
55	F231	Spacer 6" x 5/32"

TABLET DISPENSER (41-100AW)

40	41-130A	Dispenser Body.
41	41-177	Adapter 1/2"NPT x 1/2" barb
43	41-156W	Dispenser Basket
44	41-135A	Purasan Tablets (sold separately)
45	41-179	Float extension pipe (foam)
46	41-178W	Float sensor
47	RWS5A	"O" Ring
48	41-131M	Dispenser Cap (machined)
85	41-505	Cable for Float sensor

WATER Valve (221351W, 12V - 221352W, 24V)

64	221358W	Inlet hose adapter - 90°
65	221356W	Inlet hose adapter - straight
66	PX50W	Double Check Valve assembly
67	221351	Water Solenoid 12V
67	221352	Water Solenoid 24V
68	221335	1/2" Hose
69	41-157	Metering washer

AIR PUMP for tablet dispenser

162000WA (12V)

162100WA (24V)

70	166012A	12 Volt Motor
	166024A	24 Volt Motor
71	162000W	Intake Pump Assembly,air pump
72	162415A	Plug with barbed fitting
	DIAPUMP RK	Diaphragm Pump Repair Kit

CONTROLS

80	SPC	Purasan Control
81	41-500A	Wall Panel circuit board
82	221524	ME: wall panel cover,white
83	221525	ME; wall panel gasket
84	31-618	Cable for SPC wall panel
86	EFC10	ATO fuse 10A

Treatment Unit

42-1000A	Treatment Unit 12V
43-1000A	Treatment Unit 24V

62 ESTRK EST/PST Repair Kit includes following

Part No.	Description
31-102	Motor Shaft Seal (2)
31-102-1	Macerator Seal Washer
31-102-2	Macerator Retaining Ring
31-102-3	Mixer Seal Washer
31-102-4	Mixer Retaining Ring
31-103	Motor Shaft Bushing (2)
31-105	O-Ring
F351	10-32x7/8" w/ O-ring (4)
31-112	Cover Gasket
31-113-2	Terminal Block Bolt (4)
31-114	Cover Hold Down Nut, 10-32 (4)
SL1CC	Super Lube

OTHER (Not shown)

41-135A	Purasan Tablets (Refill)
PSTDCEX	Purasan Dual Control

*NOTE: 12VDC units are equipped with a 24VDC Macerator Motor

EXPLODED PARTS